

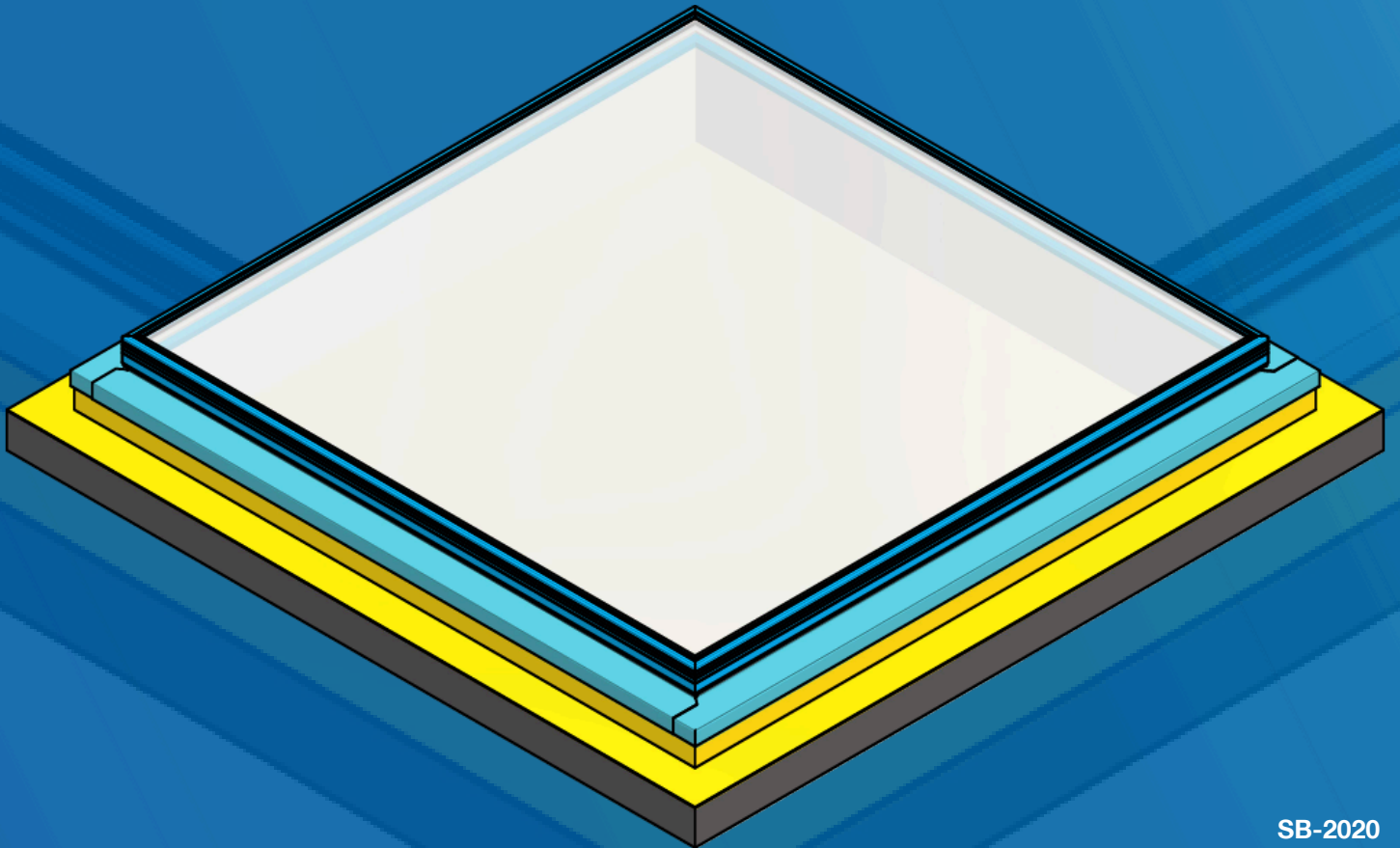

SKYSPAN
AUSTRALIA PTY LTD

Installation Instructions

GXL 0° Concrete Hob



GXL 0° Concrete Hob

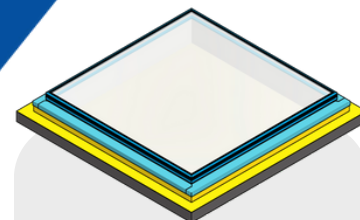

GXL 0° Concrete Hob

SUITABLE FOR SKYSPAN TRADITIONAL SKYLIGHTS

SINGLE GLAZED CODES	DOUBLE GLAZED CODES
GXL100150HB-SG	GXL100150HB-DG
GXL100200HB-SG	GXL100200HB-DG
GXL100250HB-SG	GXL100250HB-DG
GXL100300HB-SG	GXL100300HB-DG
GXL100350HB-SG	GXL100350HB-DG
GXL100400HB-SG	GXL100400HB-DG
GXL100450HB-SG	GXL100450HB-DG
GXL100500HB-SG	GXL100500HB-DG
GXL150150HB-SG	GXL150150HB-DG
GXL150200HB-SG	GXL150200HB-DG
GXL150250HB-SG	GXL150250HB-DG
GXL150300HB-SG	GXL150300HB-DG
GXL150350HB-SG	GXL150350HB-DG
GXL150400HB-SG	GXL150400HB-DG
GXL150450HB-SG	GXL150450HB-DG
GXL150500HB-SG	GXL150500HB-DG
GXL200200HB-SG	GXL200200HB-DG
GXL200250HB-SG	GXL200250HB-DG
GXL200300HB-SG	GXL200300HB-DG
GXL200350HB-SG	GXL200350HB-DG
GXL200400HB-SG	GXL200400HB-DG
GXL200450HB-SG	GXL200450HB-DG
GXL200500HB-SG	GXL200500HB-DG
GXL250250HB-SG	GXL250250HB-DG
GXL250300HB-SG	GXL250300HB-DG



01

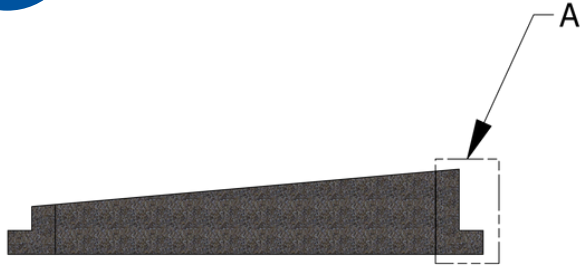

SECTION VIEW
SCALE 1 : 50

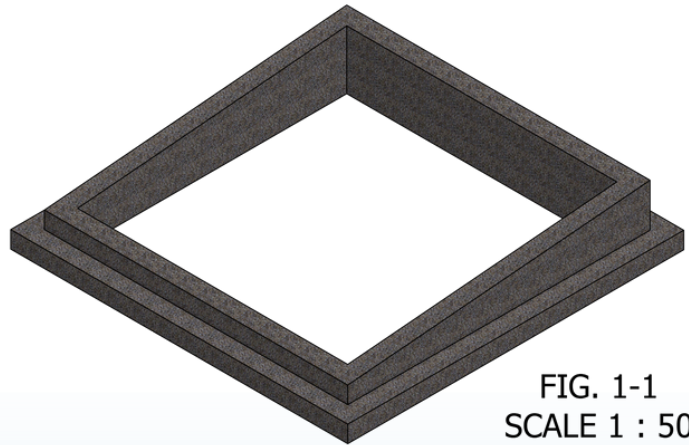
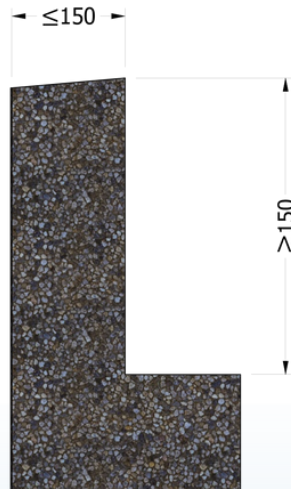

FIG. 1-1
SCALE 1 : 50

Locate and mark desired position for the skylight. Determine desired skylight dimension. Hob thickness should be 150mm but note that thickness includes the water proofing used. Refer to fig.1-2 and detail d for details.

02



See figure shown for the detailed section view of the hob and roof.



03

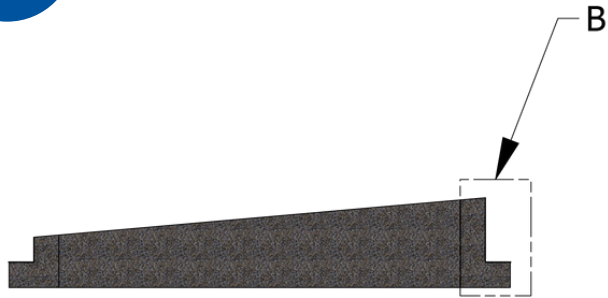

SECTION VIEW
SCALE 1 : 50

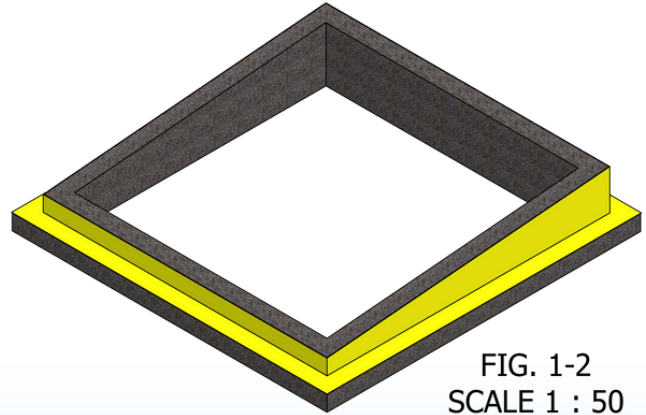
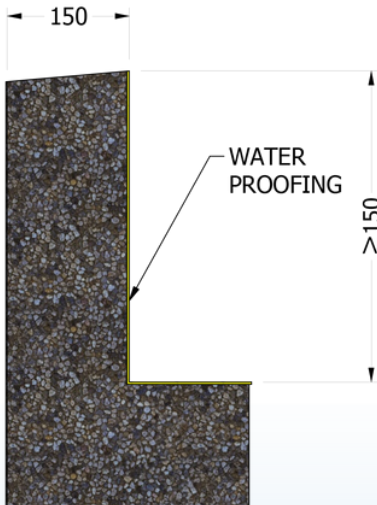

FIG. 1-2
SCALE 1 : 50

See figure above for the detailed section view of the total hob thickness including water proofing.

04



See figure shown for the detailed section view of the hob and roof detail with water proofing.

05

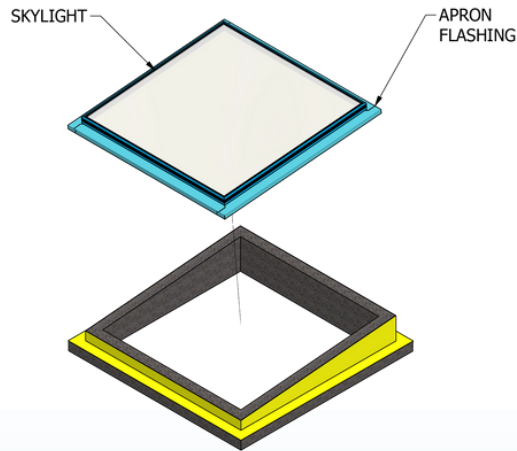
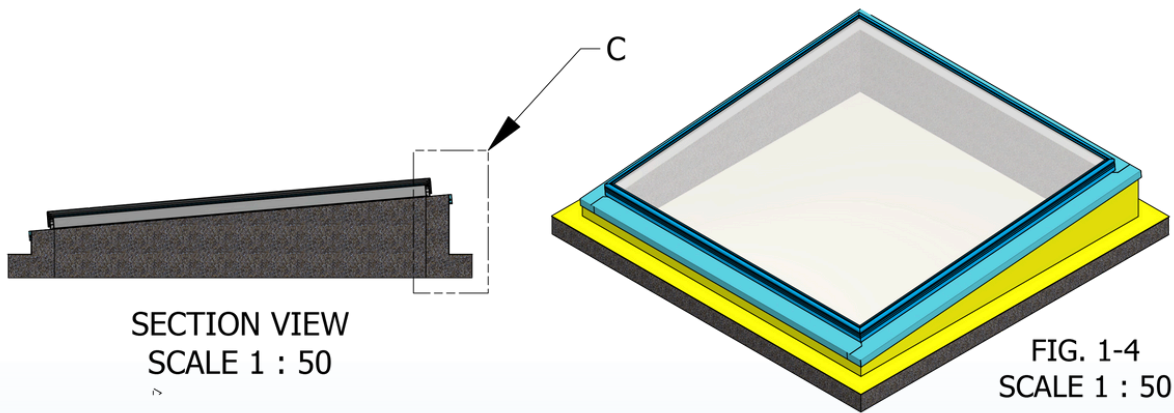

FIG. 1-3
SCALE 1 : 50

Overlap pre-assembled skylight with apron flashing to the hob.
See figure above for the pre-assembled view to be fixed.

06



SECTION VIEW
SCALE 1 : 50

FIG. 1-4
SCALE 1 : 50

Make sure the skylight is centered. Then add foam all around the hob and in between the flashing. See figure above for the assembled and section views. Refer to next figure for the detailed section view.



07

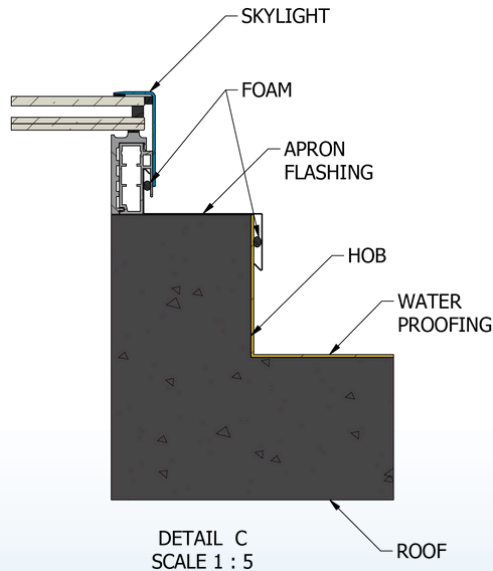

See figure shown for the detailed section view of the skylight seated on hob.

08

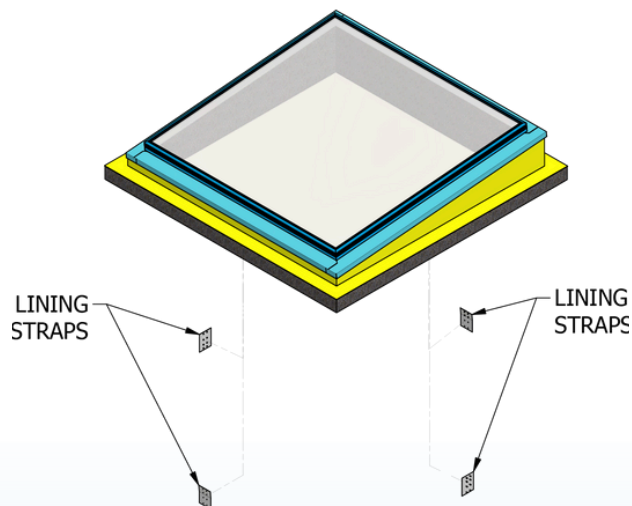

Secure skylight position by fixing lining straps to the hob. Note that quantity may vary depending on skylight size. For bigger skylight, 8 pieces of straps is needed. See figure above for quantity and location of straps to be added.

09

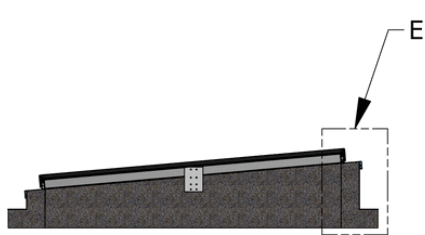

SECTION VIEW
SCALE 1 : 50

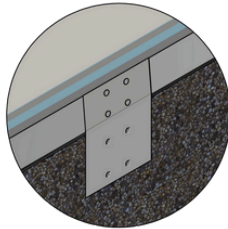

DETAIL D
SCALE 1 : 10

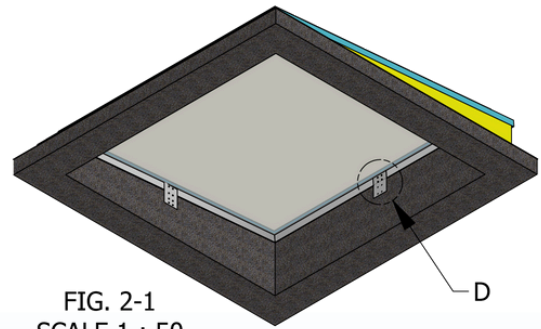
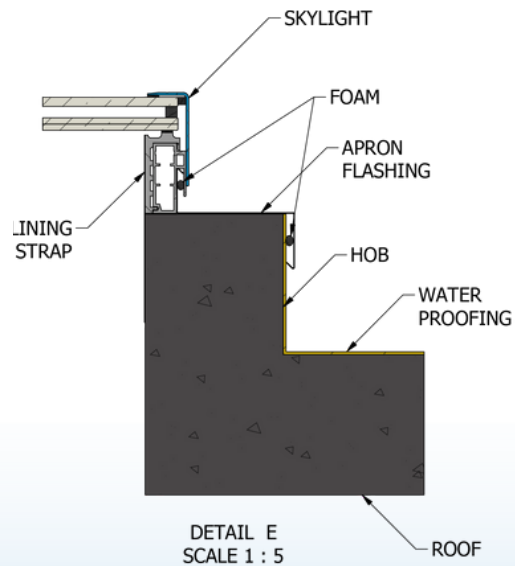

FIG. 2-1
SCALE 1 : 50

See figures above for the assembled, section, and detailed view for one corner of the assembly with straps.
Refer to next figure for the detailed section view.

10



DETAIL E
SCALE 1 : 5

See figure shown for detailed section view of the skylight being fixed with straps on hob.



11

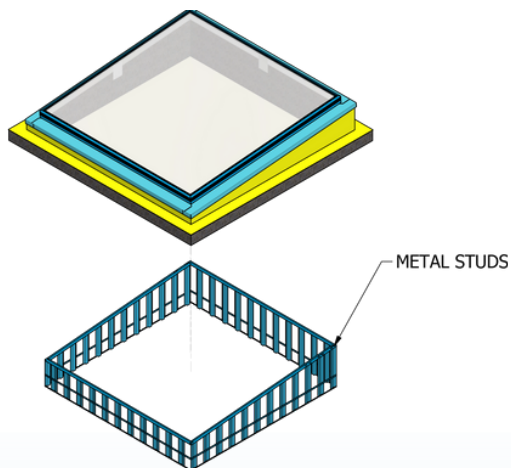
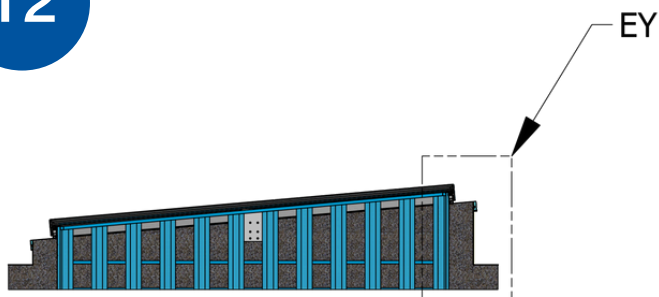

FIG. 2-2
SCALE 1 : 50

Add metal studs to concrete hob around the skylight.

12



SECTION VIEW
SCALE 1: 50

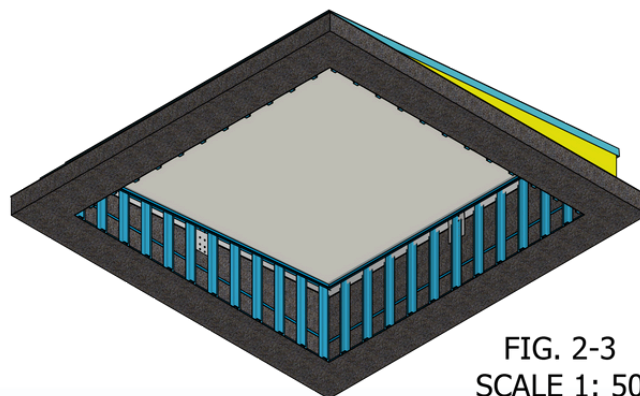
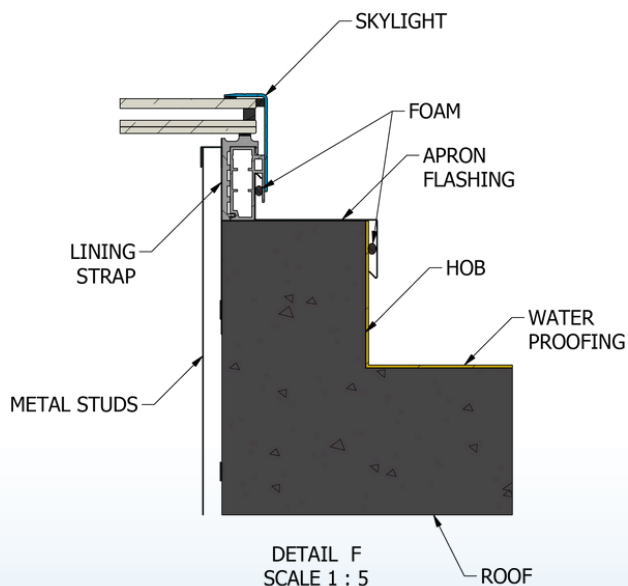

FIG. 2-3
SCALE 1: 50

See figure shown for section view and bottom view of the assembly with metal studs. Refer to next figure for the detailed section view.



13



See figure shown for detailed section view of the metal studs around the hob.

14

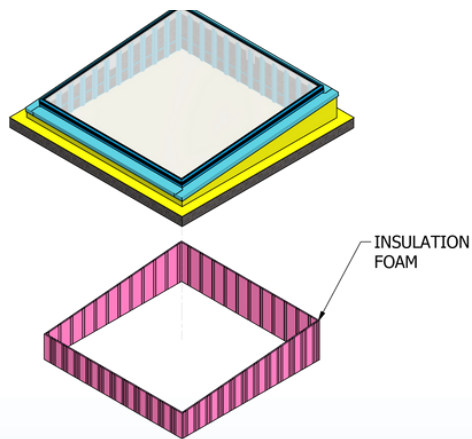
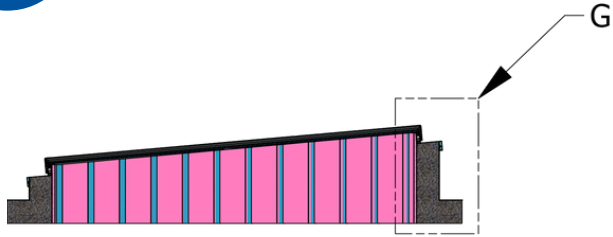

FIG. 2-4
SCALE 1 : 50

Add insulation foam in between metal studs. Secure them with the insulation strap around the Metal studs. Refer to next figures for the section view and bottom view of the assembly.

15



SECTION VIEW
SCALE 1 : 50

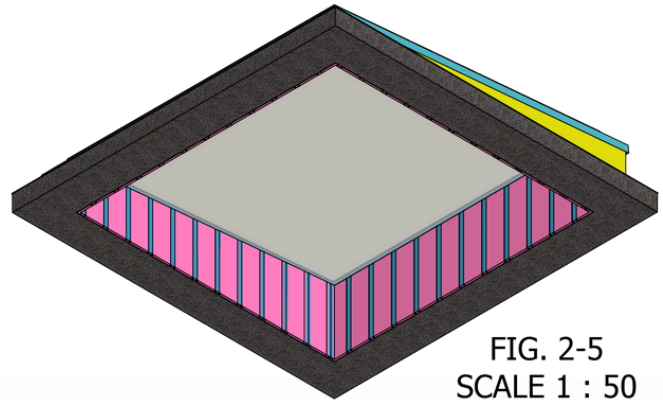
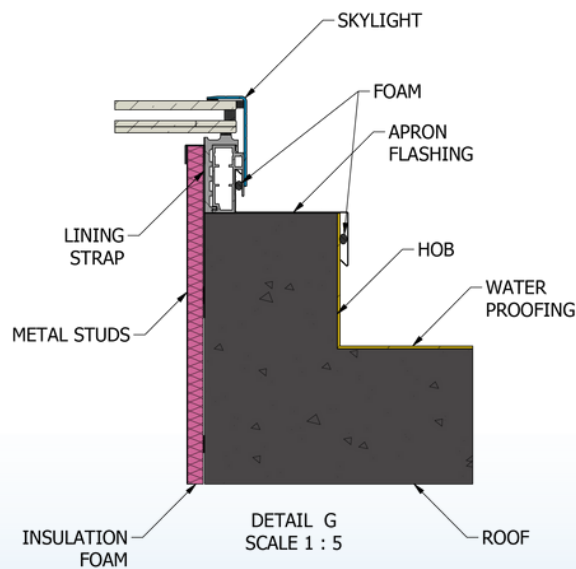

FIG. 2-5
SCALE 1 : 50

See figure shown for section view and bottom view of the assembly with insulation. Refer to next figure for the detailed section view.

16



DETAIL G
SCALE 1 : 5

See figure shown for detailed section view of the insulation in between the metal studs.



17

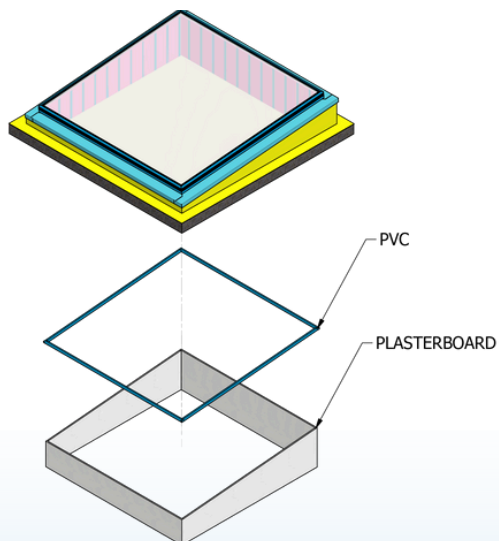

Fix plasterboard to the metal studs and add pvc cap on top all the way around the plasterboard. Refer to next figures for the section view and bottom view of the assembly.

18

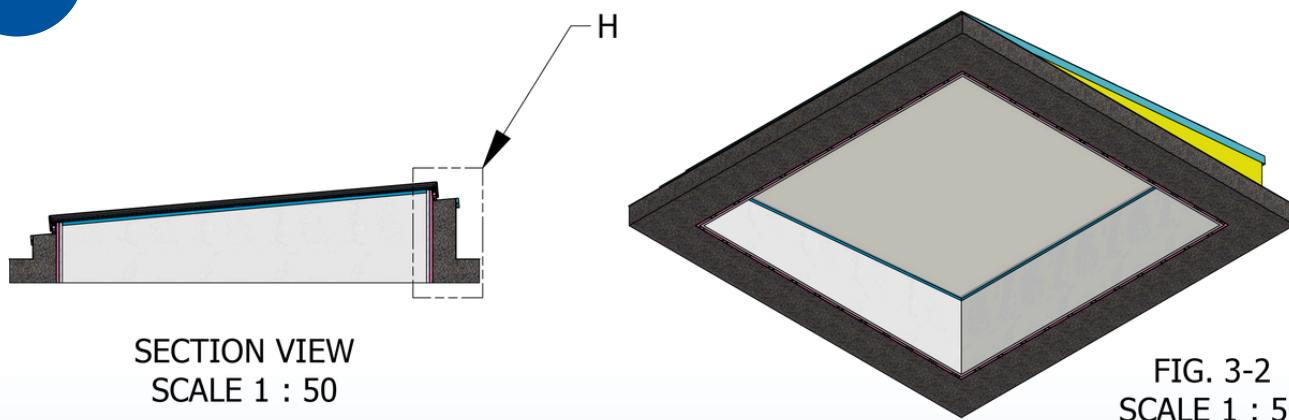

SECTION VIEW
SCALE 1 : 50

FIG. 3-2
SCALE 1 : 50

See figure shown for section view and bottom view of the assembly with plasterboard. Refer to next figure for the detailed section view.



19

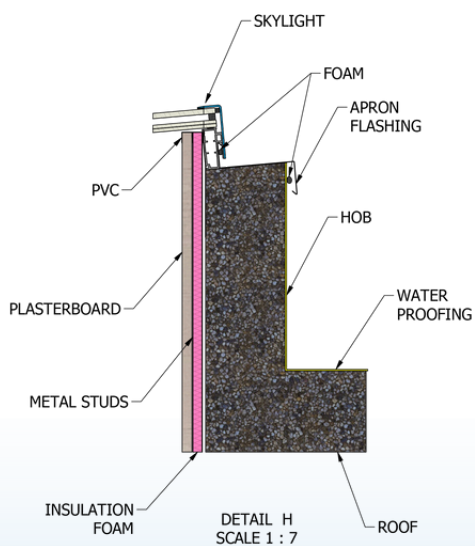

See figure shown for detailed section view for the assembly with plasterboard and cap.

20

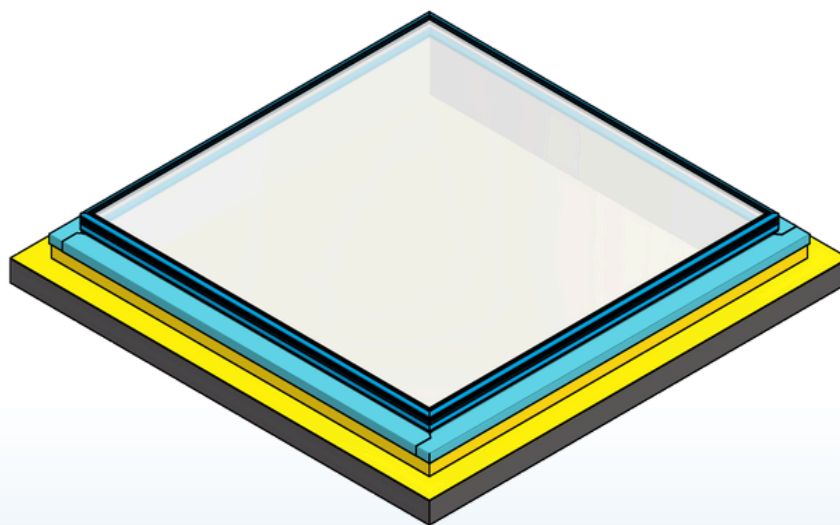

See figure above for the isometric view of the final assembly.



SKYSPAN
AUSTRALIA PTY LTD

Installation Instructions

GXL 0° Concrete Hob

1300 SKYSPAN (759 772)
customer.service@skyspan.com.au
skyspan.com.au