

TOP VIEW
SCALE 1 : 30

FRONT VIEW
SCALE 1 : 30

ISOMETRIC VIEW
SCALE 1 : 30

SECTION B-B
SCALE 1 : 30

SECTION A-A
SCALE 1 : 30

CLIENT:	DESIGNER: J.BATOON	DATE CREATED: 11/07/2023	MATERIAL:	Skyspan Australia Pty Ltd 1 Gibbon Rd, Baulkham Hills NSW 2153, Australia Website: https://www.skyspan.com.au			REVISION
BUSINESS NAME:	DRAWN BY: C.QUINOL	DATE DRAWN: 13/07/2023	THICKNESS (FOR SHEET):	PART NUMBER: SB-2060-00			A
PROJECT NAME:	MODIFIED BY:	DATE MODIFIED:	FINISH/COLOR:	TITLE: GXL - 0° CONCRETE HOB			
QUOTE NUMBER:	CHECKED BY:	CHECKED DATE:	ESTIMATED MASS: N/A	VOLUME: N/A			
WORK ORDER NUMBER:	APPROVED BY:	APPROVED DATE:			SIZE A3		
REFERENCE ORDER NUMBER:	TOLERANCES UNLESS OTHERWISE SPECIFIED IN MM		SCALE: DO NOT SCALE		FILENAME: SB-2060-00.iam	SHEET 1 OF 5	
JOB NUMBER:	FLASHING #:	<small>COPYRIGHT: THE DESIGN DETAILS SHOWN ON THIS DRAWING ARE SPECIFIC TO THIS PROJECT ONLY AND MAY NOT BE REPRODUCED IN WHOLE OR IN PART OR BE USED FOR ANY OTHER PROJECT OR PURPOSE WITHOUT THE WRITTEN CONSENT OF EVENT ENGINEERING PTY LTD. ©COPYRIGHT 2023 SKYSPAN</small>					
	FLASHING QTY:						

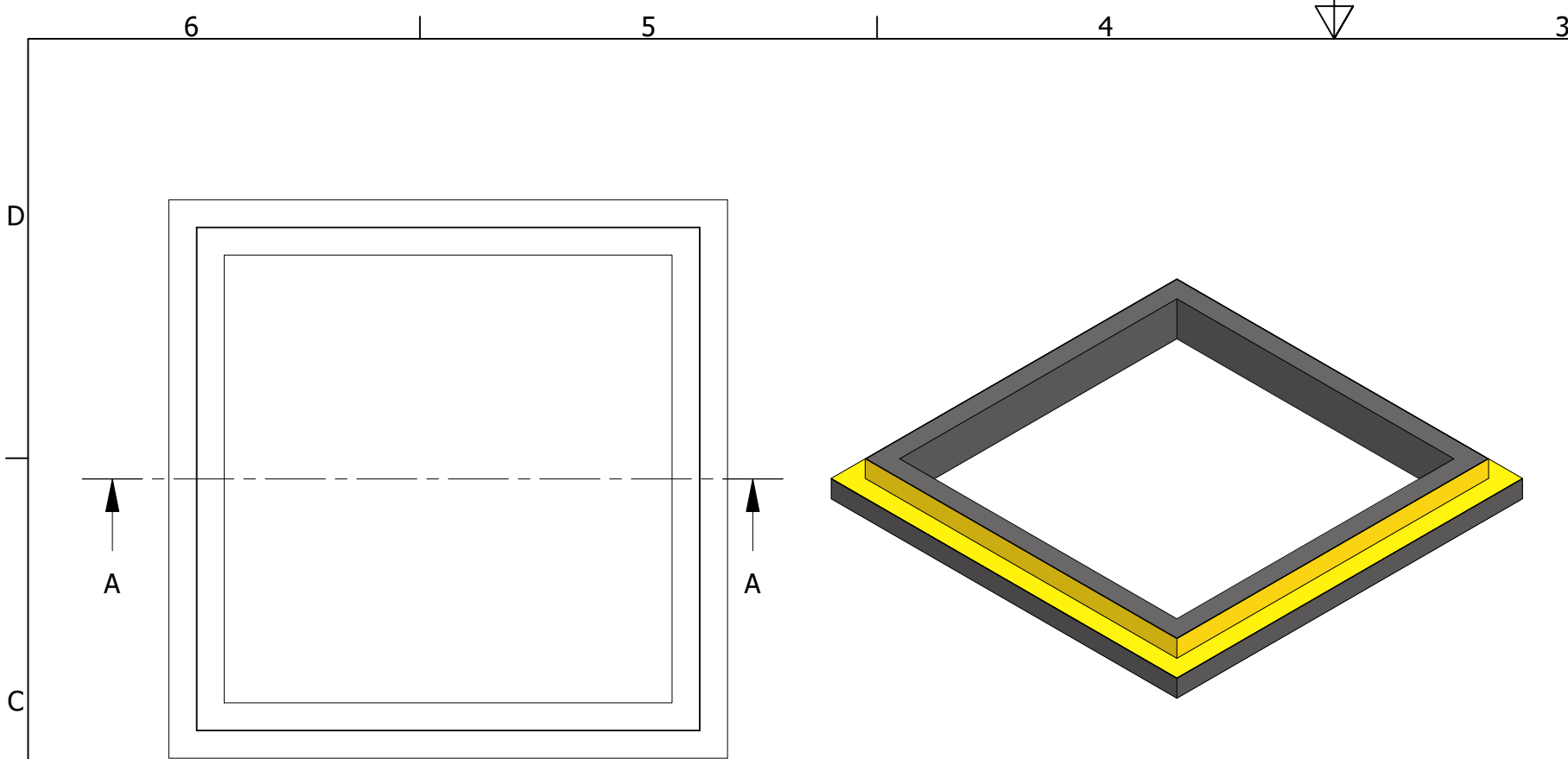

TOP VIEW
SCALE 1 : 35

ISOMETRIC VIEW
SCALE 1 : 40

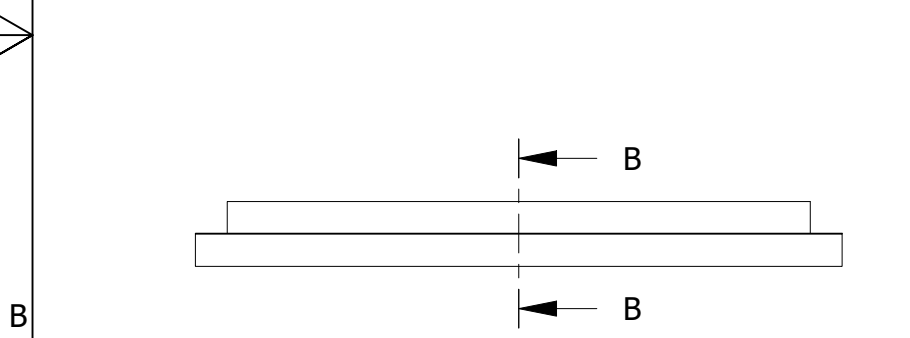

FRONT VIEW
SCALE 1 : 35

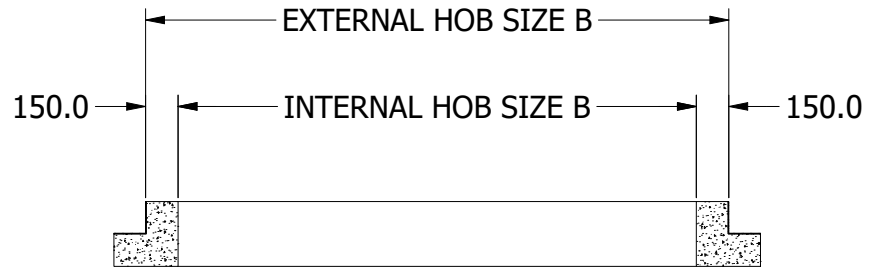

SECTION B-B
SCALE 1 : 35

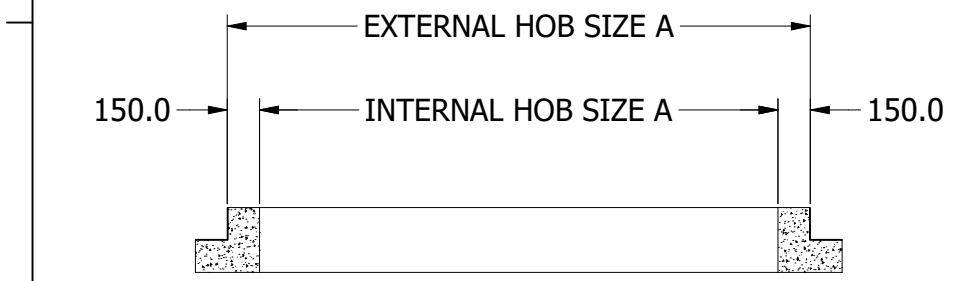

SECTION A-A
SCALE 1 : 35

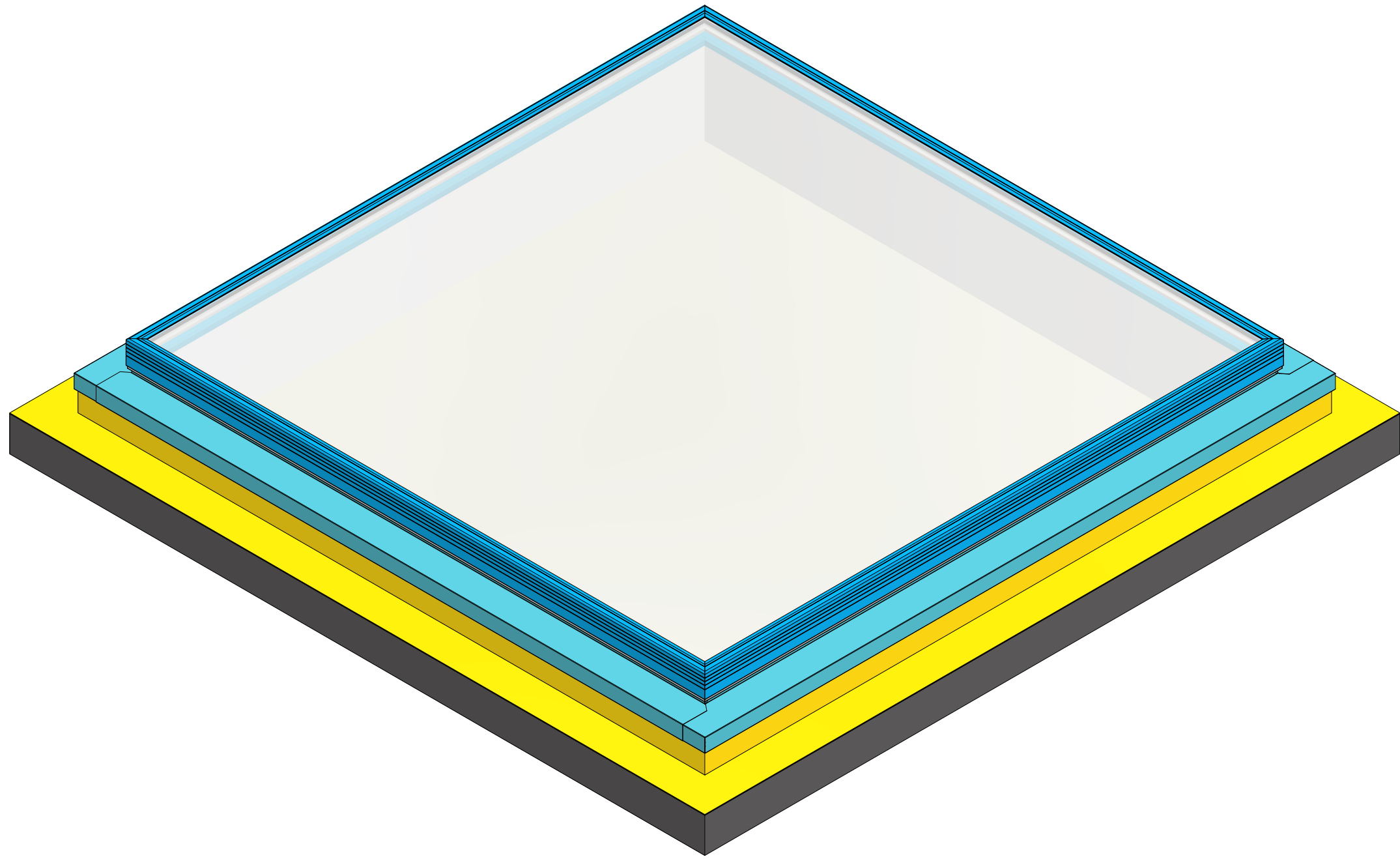

SKYLIGHT CODES AND HOB SIZES					
SINGLE GLAZED	DOUBLE GLAZED	INTERNAL HOB SIZE A (mm)	INTERNAL HOB SIZE B (mm)	EXTERNAL HOB SIZE A (mm)	EXTERNAL HOB SIZE B (mm)
GXL100150AU-SG	GXL100150AU-DG	1000	1500	1300	1800
GXL100200AU-SG	GXL100200AU-DG	1000	2000	1300	2300
GXL100250AU-SG	GXL100250AU-DG	1000	2500	1300	2800
GXL100300AU-SG	GXL100300AU-DG	1000	3000	1300	3300
GXL100350AU-SG	GXL100350AU-DG	1000	3500	1300	3800
GXL100400AU-SG	GXL100400AU-DG	1000	4000	1300	4300
GXL100450AU-SG	GXL100450AU-DG	1000	4500	1300	4800
GXL100500AU-SG	GXL100500AU-DG	1000	5000	1300	5300
GXL150150AU-SG	GXL150150AU-DG	1500	1500	1800	1800
GXL150200AU-SG	GXL150200AU-DG	1500	2000	1800	2300
GXL150250AU-SG	GXL150250AU-DG	1500	2500	1800	2800
GXL150300AU-SG	GXL150300AU-DG	1500	3000	1800	3300
GXL150350AU-SG	GXL150350AU-DG	1500	3500	1800	3800
GXL150400AU-SG	GXL150400AU-DG	1500	4000	1800	4300
GXL150450AU-SG	GXL150450AU-DG	1500	4500	1800	4800
GXL150500AU-SG	GXL150500AU-DG	1500	5000	1800	5300
GXL200200AU-SG	GXL200200AU-DG	2000	2000	2300	2300
GXL200250AU-SG	GXL200250AU-DG	2000	2500	2300	2800
GXL200300AU-SG	GXL200300AU-DG	2000	3000	2300	3300
GXL200350AU-SG	GXL200350AU-DG	2000	3500	2300	3800
GXL200400AU-SG	GXL200400AU-DG	2000	4000	2300	4300
GXL200450AU-SG	GXL200450AU-DG	2000	4500	2300	4800
GXL200500AU-SG	GXL200500AU-DG	2000	5000	2300	5300
GXL250250AU-SG	GXL250250AU-DG	2500	2500	2800	2800
GXL250300AU-SG	GXL250300AU-DG	2500	3000	2800	3300
GXL250350AU-SG	GXL250350AU-DG	2500	3500	2800	3800
GXL250400AU-SG	GXL250400AU-DG	2500	4000	2800	4300
GXL250450AU-SG	GXL250450AU-DG	2500	4500	2800	4800
GXL250500AU-SG	GXL250500AU-DG	2500	5000	2800	5300

CLIENT:	DESIGNER: J.BATOON	DATE CREATED: 11/07/2023	MATERIAL:	Skyspan Australia Pty Ltd 1 Gibbon Rd, Baulkham Hills NSW 2153, Australia Website: https://www.skyspan.com.au	
BUSINESS NAME:	DRAWN BY: C.QUINOL	DATE DRAWN: 13/07/2023	THICKNESS (FOR SHEET):		
PROJECT NAME:	MODIFIED BY:	DATE MODIFIED:	FINISH/COLOR:	PART NUMBER: SB-2060-00	REVISION A
QUOTE NUMBER:	CHECKED BY:	CHECKED DATE:	ESTIMATED MASS: N/A	VOLUME: N/A	
WORK ORDER NUMBER:	APPROVED BY:	APPROVED DATE:	SIZE A3	TITLE: GXL - 0° CONCRETE HOB	
REFERENCE ORDER NUMBER:	TOLERANCES UNLESS OTHERWISE SPECIFIED IN MM		THIRD ANGLE PROJECTION	SCALE: DO NOT SCALE	FILENAME: SB-2060-00.iam
JOB NUMBER:	FLASHING #:	COPYRIGHT: THE DESIGN DETAILS SHOWN ON THIS DRAWING ARE SPECIFIC TO THIS PROJECT ONLY AND MAY NOT BE REPRODUCED IN WHOLE OR IN PART OR BE USED FOR ANY OTHER PROJECT OR PURPOSE WITHOUT THE WRITTEN CONSENT OF EVENT ENGINEERING PTY LTD. ©COPYRIGHT 2023 SKYSPAN		SHEET 2 OF 5	



ISOMETRIC VIEW
SCALE 1 : 15

Note: Waterproofing example shown as yellow is by others.

CLIENT:	DESIGNER: J.BATOON	DATE CREATED: 11/07/2023	MATERIAL:	Skyspan Australia Pty Ltd 1 Gibbon Rd, Baulkham Hills NSW 2153, Australia Website: https://www.skyspan.com.au		
BUSINESS NAME:	DRAWN BY: C.QUINOL	DATE DRAWN: 13/07/2023	THICKNESS (FOR SHEET):	PART NUMBER: SB-2060-00		
PROJECT NAME:	MODIFIED BY:	DATE MODIFIED:	FINISH/COLOR:	ESTIMATED MASS: N/A		VOLUME: N/A
QUOTE NUMBER:	CHECKED BY:	CHECKED DATE:	ESTIMATED MASS: N/A	APPROVED BY:		APPROVED DATE:
WORK ORDER NUMBER:	APPROVED BY:	APPROVED DATE:	ESTIMATED MASS: N/A	SIZE A3		TITLE: GXL - 0° CONCRETE HOB
REFERENCE ORDER NUMBER:	TOLERANCES UNLESS OTHERWISE SPECIFIED IN MM				SCALE: DO NOT SCALE	FILENAME: SB-2060-00.iam
JOB NUMBER:	FLASHING #:	COPYRIGHT: THE DESIGN DETAILS SHOWN ON THIS DRAWING ARE SPECIFIC TO THIS PROJECT ONLY AND MAY NOT BE REPRODUCED IN WHOLE OR IN PART OR BE USED FOR ANY OTHER PROJECT OR PURPOSE WITHOUT THE WRITTEN CONSENT OF EVENT ENGINEERING PTY LTD. ©COPYRIGHT 2023 SKYSPAN		SHEET 3 OF 5		
	FLASHING QTY:					

6 5 4 3 2 1

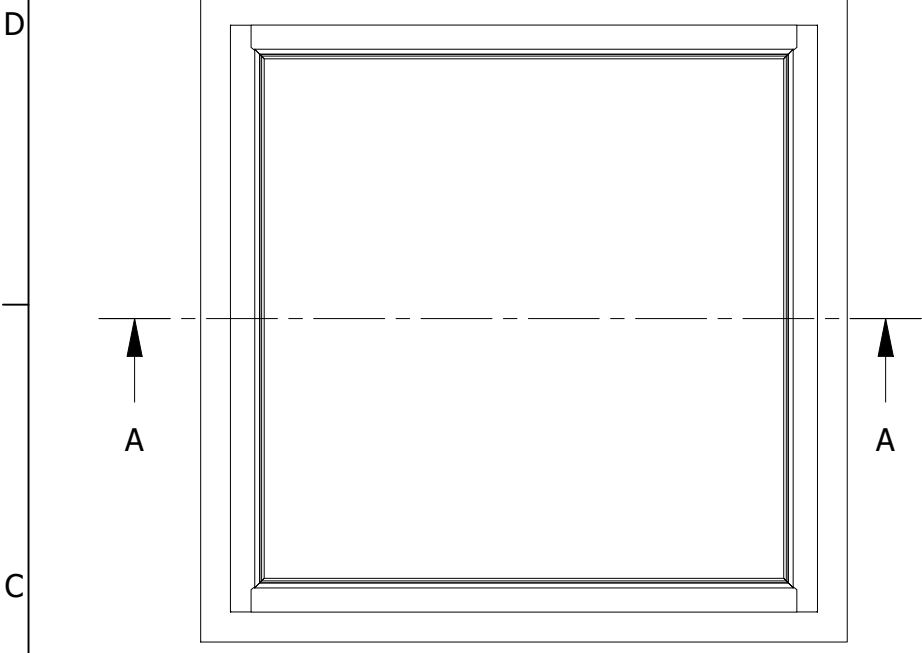

TOP VIEW
SCALE 1 : 35

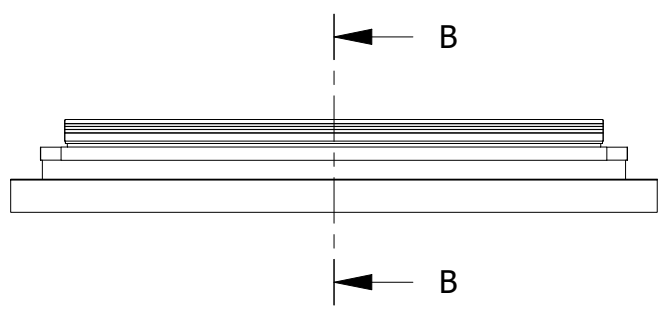

FRONT VIEW
SCALE 1 : 35

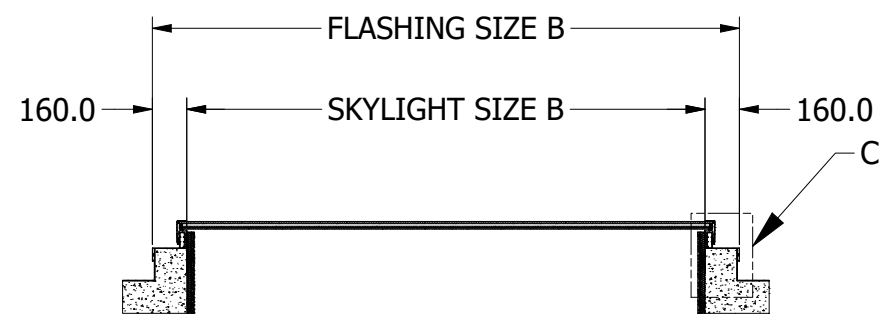

SECTION B-B
SCALE 1 : 35

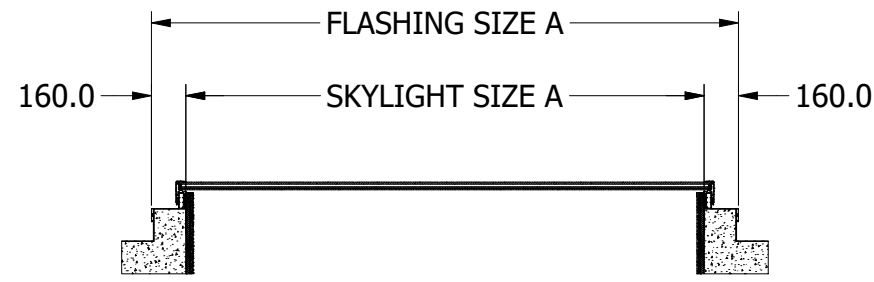

SECTION A-A
SCALE 1 : 35

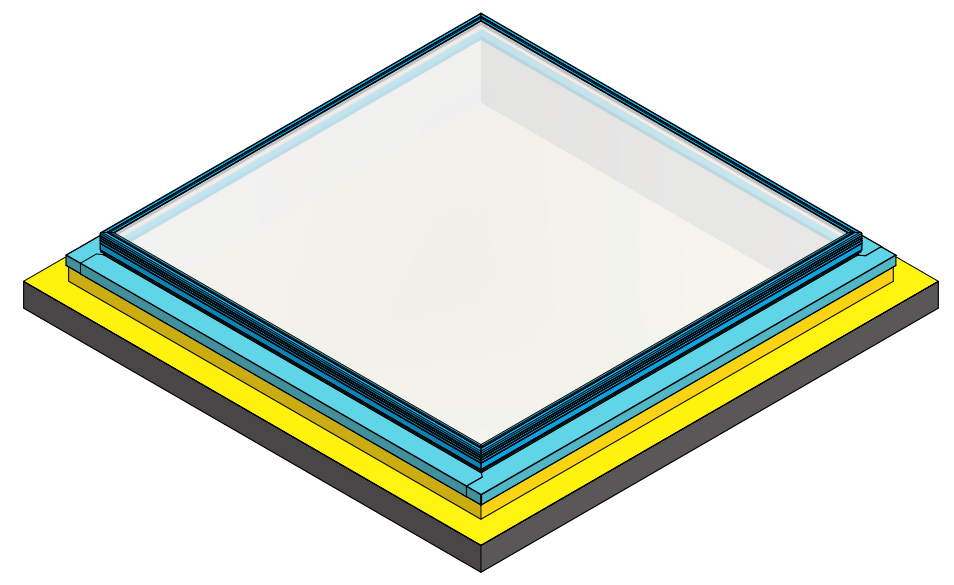

ISOMETRIC VIEW
SCALE 1 : 35

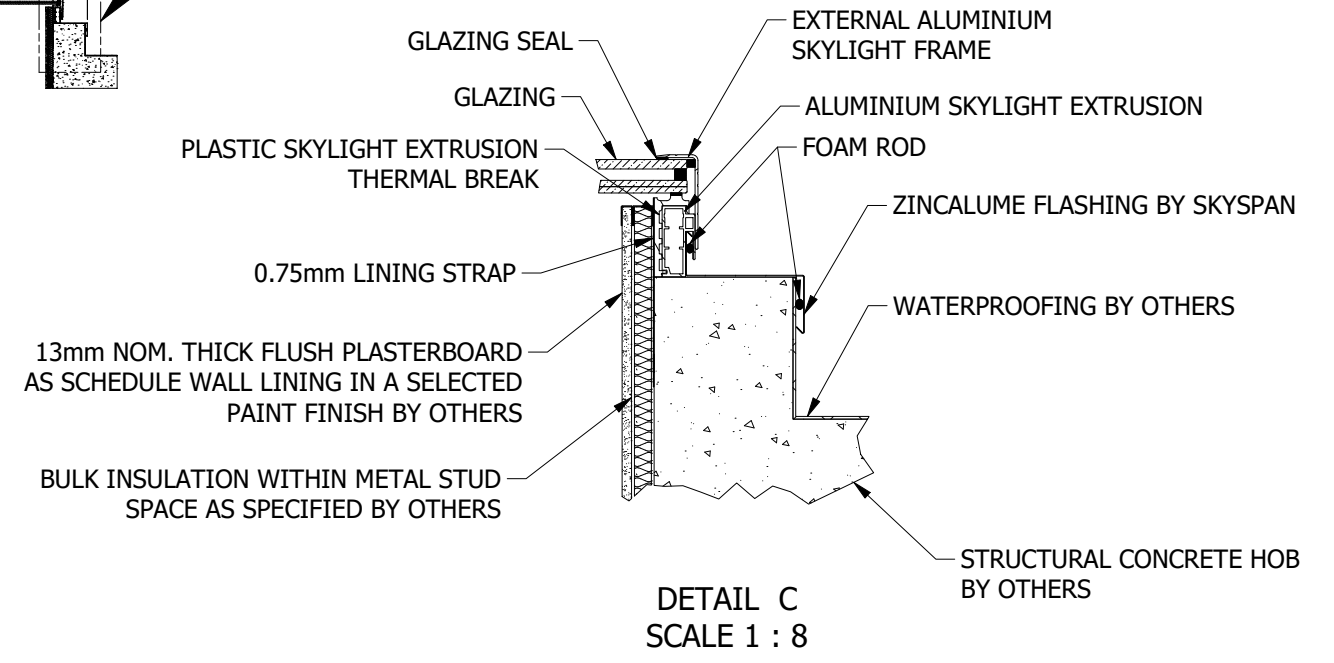

DETAIL C
SCALE 1 : 8

CLIENT:	DESIGNER: J.BATOON	DATE CREATED: 11/07/2023	MATERIAL:	Skyspan Australia Pty Ltd 1 Gibbon Rd, Baulkham Hills NSW 2153, Australia Website: https://www.skyspan.com.au	
BUSINESS NAME:	DRAWN BY: C.QUINOL	DATE DRAWN: 13/07/2023	THICKNESS (FOR SHEET):		
PROJECT NAME:	MODIFIED BY:	DATE MODIFIED:	FINISH/COLOR:	PART NUMBER: SB-2060-00	REVISION A
QUOTE NUMBER:	CHECKED BY:	CHECKED DATE:	ESTIMATED MASS: N/A	VOLUME: N/A	
WORK ORDER NUMBER:	APPROVED BY:	APPROVED DATE:	SIZE A3	TITLE: GXL - 0° CONCRETE HOB	
REFERENCE ORDER NUMBER:	TOLERANCES UNLESS OTHERWISE SPECIFIED IN MM			SCALE: DO NOT SCALE	FILENAME: SB-2060-00.iam
JOB NUMBER:	FLASHING #:	COPYRIGHT: THE DESIGN DETAILS SHOWN ON THIS DRAWING ARE SPECIFIC TO THIS PROJECT ONLY AND MAY NOT BE REPRODUCED IN WHOLE OR IN PART OR BE USED FOR ANY OTHER PROJECT OR PURPOSE WITHOUT THE WRITTEN CONSENT OF EVENT ENGINEERING PTY LTD. ©COPYRIGHT 2023 SKYSPAN			SHEET 4 OF 5
	FLASHING QTY:				

6 5 4 3 2 1

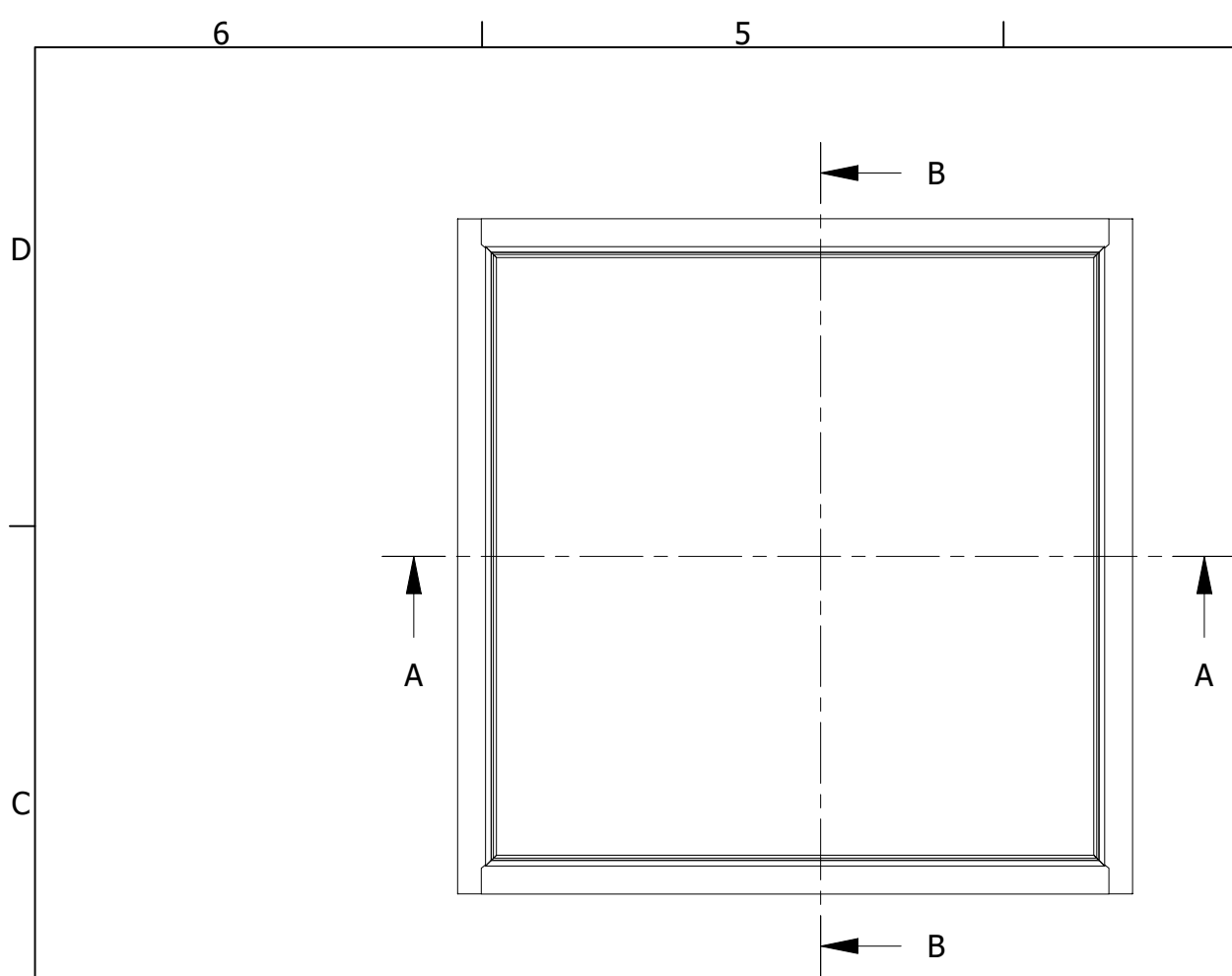

TOP VIEW
SCALE 1 : 30

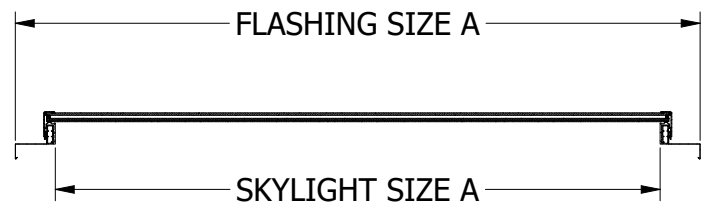

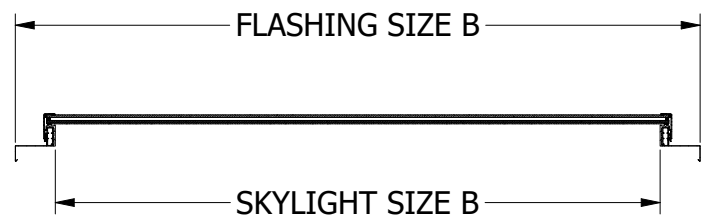

SECTION A-A
SCALE 1 : 30



SECTION B-B
SCALE 1 : 30

SKYLIGHT CODES AND SIZES					
SINGLE GLAZED	DOUBLE GLAZED	SKYLIGHT SIZE A (mm)	SKYLIGHT SIZE B (mm)	FLASHING SIZE A (mm)	FLASHING SIZE B (mm)
GXL100150AU-SG	GXL100150AU-DG	1000	1500	1320	1820
GXL100200AU-SG	GXL100200AU-DG	1000	2000	1320	2320
GXL100250AU-SG	GXL100250AU-DG	1000	2500	1320	2820
GXL100300AU-SG	GXL100300AU-DG	1000	3000	1320	3320
GXL100350AU-SG	GXL100350AU-DG	1000	3500	1320	3820
GXL100400AU-SG	GXL100400AU-DG	1000	4000	1320	4320
GXL100450AU-SG	GXL100450AU-DG	1000	4500	1320	4820
GXL100500AU-SG	GXL100500AU-DG	1000	5000	1320	5320
GXL150150AU-SG	GXL150150AU-DG	1500	1500	1820	1820
GXL150200AU-SG	GXL150200AU-DG	1500	2000	1820	2320
GXL150250AU-SG	GXL150250AU-DG	1500	2500	1820	2820
GXL150300AU-SG	GXL150300AU-DG	1500	3000	1820	3320
GXL150350AU-SG	GXL150350AU-DG	1500	3500	1820	3820
GXL150400AU-SG	GXL150400AU-DG	1500	4000	1820	4320
GXL150450AU-SG	GXL150450AU-DG	1500	4500	1820	4820
GXL150500AU-SG	GXL150500AU-DG	1500	5000	1820	5320
GXL200200AU-SG	GXL200200AU-DG	2000	2000	2320	2320
GXL200250AU-SG	GXL200250AU-DG	2000	2500	2320	2820
GXL200300AU-SG	GXL200300AU-DG	2000	3000	2320	3320
GXL200350AU-SG	GXL200350AU-DG	2000	3500	2320	3820
GXL200400AU-SG	GXL200400AU-DG	2000	4000	2320	4320
GXL200450AU-SG	GXL200450AU-DG	2000	4500	2320	4820
GXL200500AU-SG	GXL200500AU-DG	2000	5000	2320	5320
GXL250250AU-SG	GXL250250AU-DG	2500	2500	2820	2820
GXL250300AU-SG	GXL250300AU-DG	2500	3000	2820	3320
GXL250350AU-SG	GXL250350AU-DG	2500	3500	2820	3820
GXL250400AU-SG	GXL250400AU-DG	2500	4000	2820	4320
GXL250450AU-SG	GXL250450AU-DG	2500	4500	2820	4820
GXL250500AU-SG	GXL250500AU-DG	2500	5000	2820	5320

CLIENT:	DESIGNER: J.BATOON	DATE CREATED: 11/07/2023	MATERIAL:	Skyspan Australia Pty Ltd 1 Gibbon Rd, Baulkham Hills NSW 2153, Australia Website: https://www.skyspan.com.au 	
BUSINESS NAME:	DRAWN BY: C.QUINOL	DATE DRAWN: 13/07/2023	THICKNESS (FOR SHEET):	PART NUMBER: SB-2060-00	
PROJECT NAME:	MODIFIED BY:	DATE MODIFIED:	FINISH/COLOR:	REVISION: A	
QUOTE NUMBER:	CHECKED BY:	CHECKED DATE:	ESTIMATED MASS: N/A	VOLUME: N/A	TITLE: GXL - 0° CONCRETE HOB
WORK ORDER NUMBER:	APPROVED BY:	APPROVED DATE:	SCALE: DO NOT SCALE	SIZE A3	FILENAME: SB-2060-00.iam
REFERENCE ORDER NUMBER:	<small>TOLERANCES UNLESS OTHERWISE SPECIFIED IN MM</small>			SHEET 5 OF 5	
JOB NUMBER:	FLASHING #:	<small>COPYRIGHT: THE DESIGN DETAILS SHOWN ON THIS DRAWING ARE SPECIFIC TO THIS PROJECT ONLY AND MAY NOT BE REPRODUCED IN WHOLE OR IN PART OR BE USED FOR ANY OTHER PROJECT OR PURPOSE WITHOUT THE WRITTEN CONSENT OF EVENT ENGINEERING PTY LTD. ©COPYRIGHT 2023 SKYSPAN</small>			
	FLASHING QTY:				