

FILL IN ALL BOXES PROVIDED.

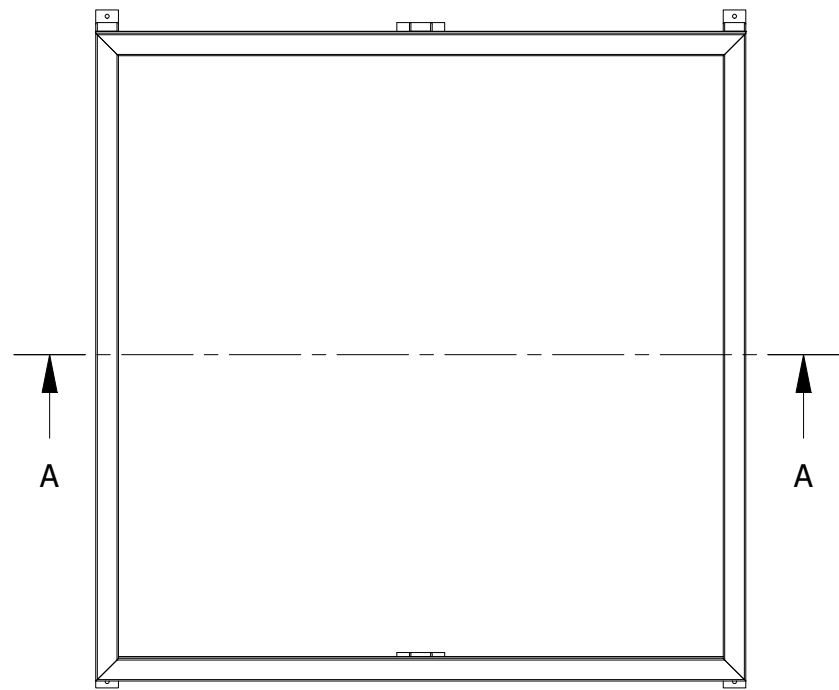

TOP VIEW  
SCALE 1 : 30

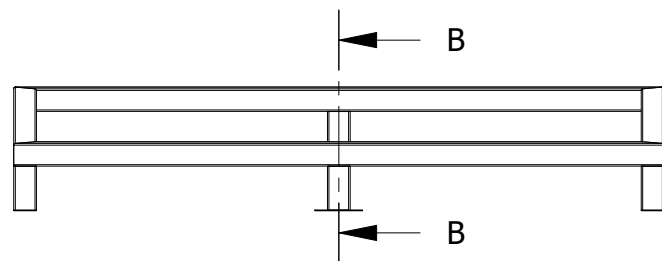

FRONT VIEW  
SCALE 1 : 30

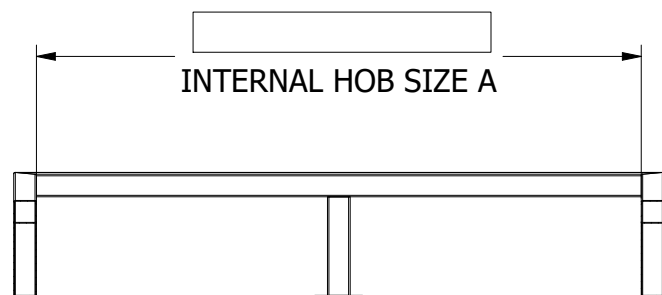

SECTION A-A  
SCALE 1 : 30

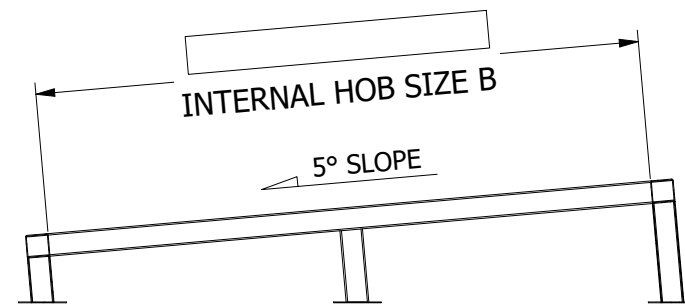

SECTION B-B  
SCALE 1 : 30

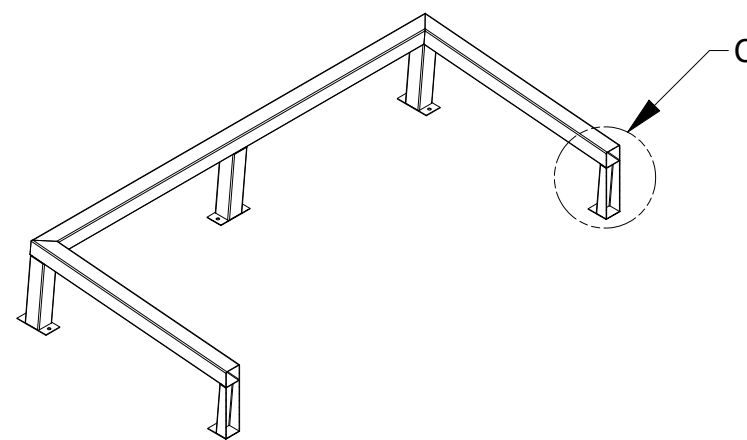

SECTION A-A (ISOMETRIC)  
SCALE 1 : 35

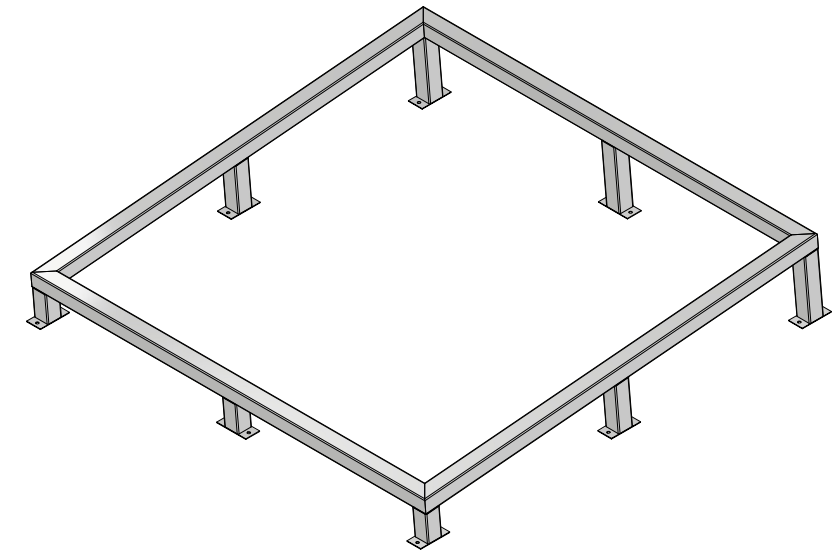

ISOMETRIC VIEW  
SCALE 1 : 35

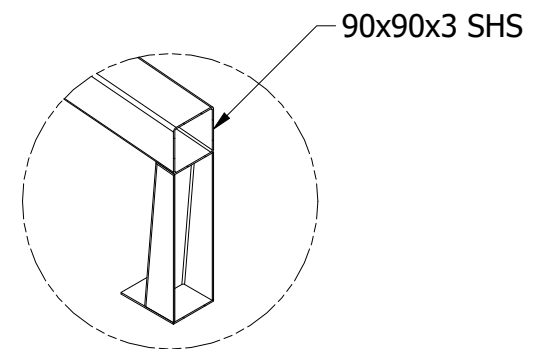

DETAIL C  
SCALE 1 : 12

**Client Drawing Approval**

Name:

Signature:

Date:

CLIENT:	DESIGNER: C.QUINOL	DATE CREATED: 10/07/2023	MATERIAL:	Skyspan Australia Pty Ltd 1 Gibbon Rd, Baulkham Hills NSW 2153, Australia Website: https://www.skyspan.com.au	
BUSINESS NAME:	DRAWN BY: C.QUINOL	DATE DRAWN: 19/02/2024	THICKNESS (FOR SHEET):		
PROJECT NAME:	MODIFIED BY: M.AMIT	DATE MODIFIED: 08/03/2024	FINISH/COLOR:	PART NUMBER: SB-2049-00	REVISION A
QUOTE NUMBER:	CHECKED BY:	CHECKED DATE:	ESTIMATED MASS: N/A	VOLUME: N/A	
WORK ORDER NUMBER:	APPROVED BY:	APPROVED DATE:	SIZE A3	TITLE: GXL - 5° STEEL HOB	
REFERENCE ORDER NUMBER:	TOLERANCES UNLESS OTHERWISE SPECIFIED IN MM COPYRIGHT: THE DESIGN DETAILS SHOWN ON THIS DRAWING ARE SPECIFIC TO THIS PROJECT ONLY AND MAY NOT BE REPRODUCED IN WHOLE OR IN PART OR BE USED FOR ANY OTHER PROJECT OR PURPOSE WITHOUT THE WRITTEN CONSENT OF SKYSPAN AUSTRALIA PTY LTD. ©COPYRIGHT 2024 SKYSPAN			SCALE: DO NOT SCALE	FILENAME: SB-2049-00.iam
JOB NUMBER:	FLASHING #:	FLASHING QTY:	THIRD ANGLE PROJECTION		SHEET 1 OF 8

This Skylight system is covered by Australian Patent Pending Number 2021901063 and New Zealand Patent Pending Number 774968.

FILL IN ALL BOXES PROVIDED.

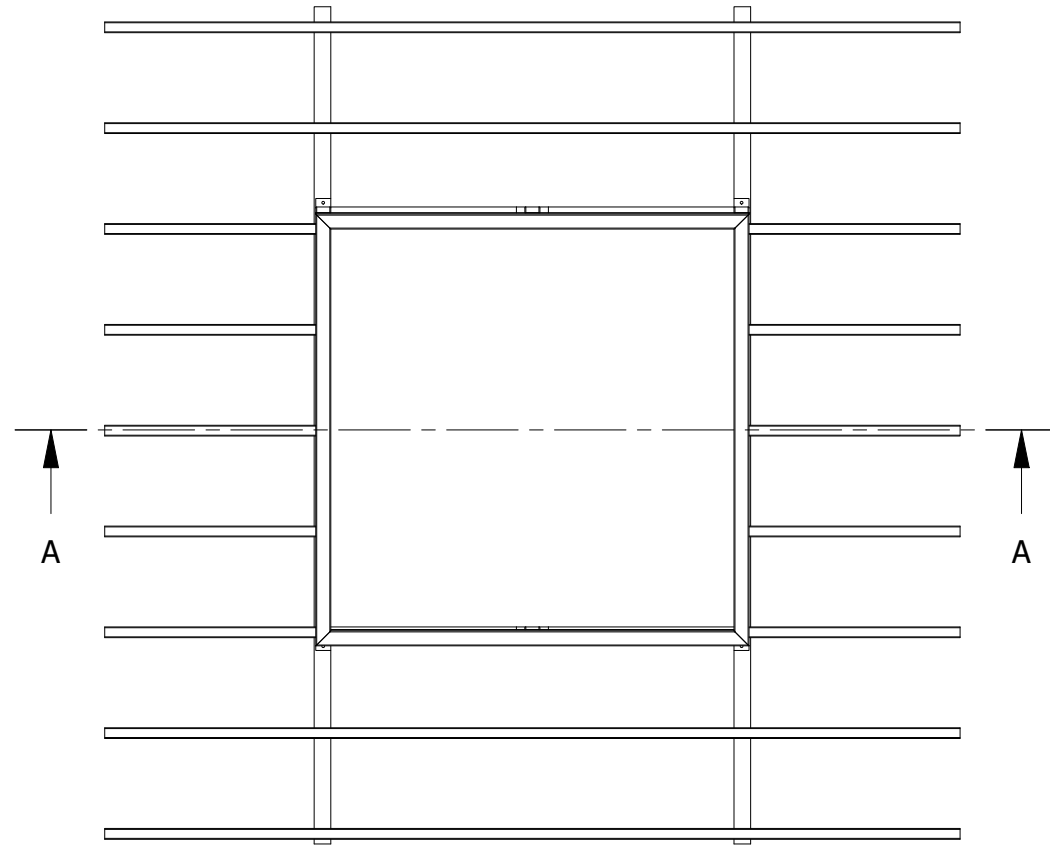

TOP VIEW  
SCALE 1 : 45

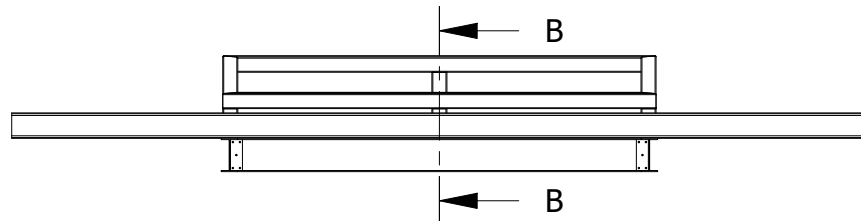

FRONT VIEW  
SCALE 1 : 45

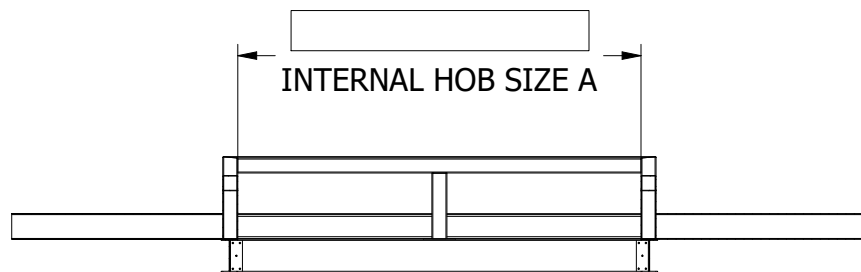

SECTION A-A  
SCALE 1 : 45

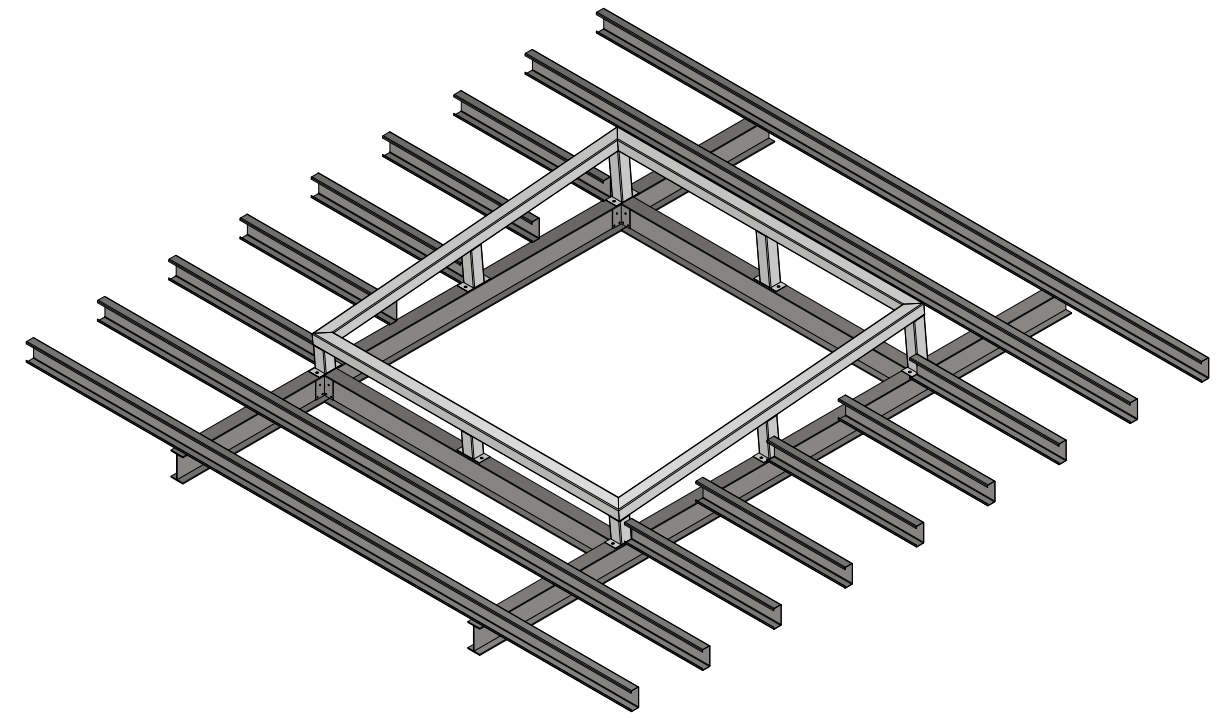

ISOMETRIC VIEW  
SCALE 1 : 45

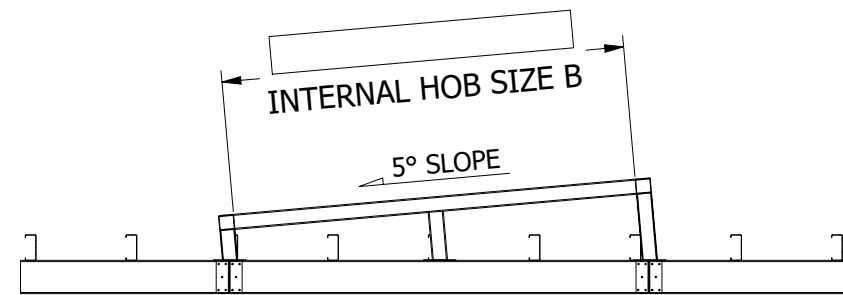

SECTION B-B  
SCALE 1 : 45

**Client Drawing Approval**  
**Name:**   
**Signature:**   
**Date:**

CLIENT:	DESIGNER: C.QUINOL	DATE CREATED: 10/07/2023	MATERIAL:	<b>Skyspan Australia Pty Ltd</b> 1 Gibbon Rd, Baulkham Hills NSW 2153, Australia Website: <a href="https://www.skyspan.com.au">https://www.skyspan.com.au</a>	
BUSINESS NAME:	DRAWN BY: C.QUINOL	DATE DRAWN: 19/02/2024	THICKNESS (FOR SHEET):		
PROJECT NAME:	MODIFIED BY: M.AMIT	DATE MODIFIED: 08/03/2024	FINISH/COLOR:	PART NUMBER: SB-2049-00	REVISION: A
QUOTE NUMBER:	CHECKED BY:	CHECKED DATE:	ESTIMATED MASS: N/A	VOLUME: N/A	
WORK ORDER NUMBER:	APPROVED BY:	APPROVED DATE:	SIZE: A3	TITLE: GXL - 5° STEEL HOB	
REFERENCE ORDER NUMBER:	TOLERANCES UNLESS OTHERWISE SPECIFIED IN MM		THIRD ANGLE PROJECTION	SCALE: DO NOT SCALE	FILENAME: SB-2049-00.iam
JOB NUMBER:	FLASHING #:	COPYRIGHT: THE DESIGN DETAILS SHOWN ON THIS DRAWING ARE SPECIFIC TO THIS PROJECT ONLY AND MAY NOT BE REPRODUCED IN WHOLE OR IN PART OR BE USED FOR ANY OTHER PROJECT OR PURPOSE WITHOUT THE WRITTEN CONSENT OF SKYSPAN AUSTRALIA PTY LTD. ©COPYRIGHT 2024 SKYSPAN			SHEET 2 OF 8
	FLASHING QTY:				

This Skylight system is covered by Australian Patent Pending Number 2021901063 and New Zealand Patent Pending Number 774968.

FILL IN ALL BOXES PROVIDED.

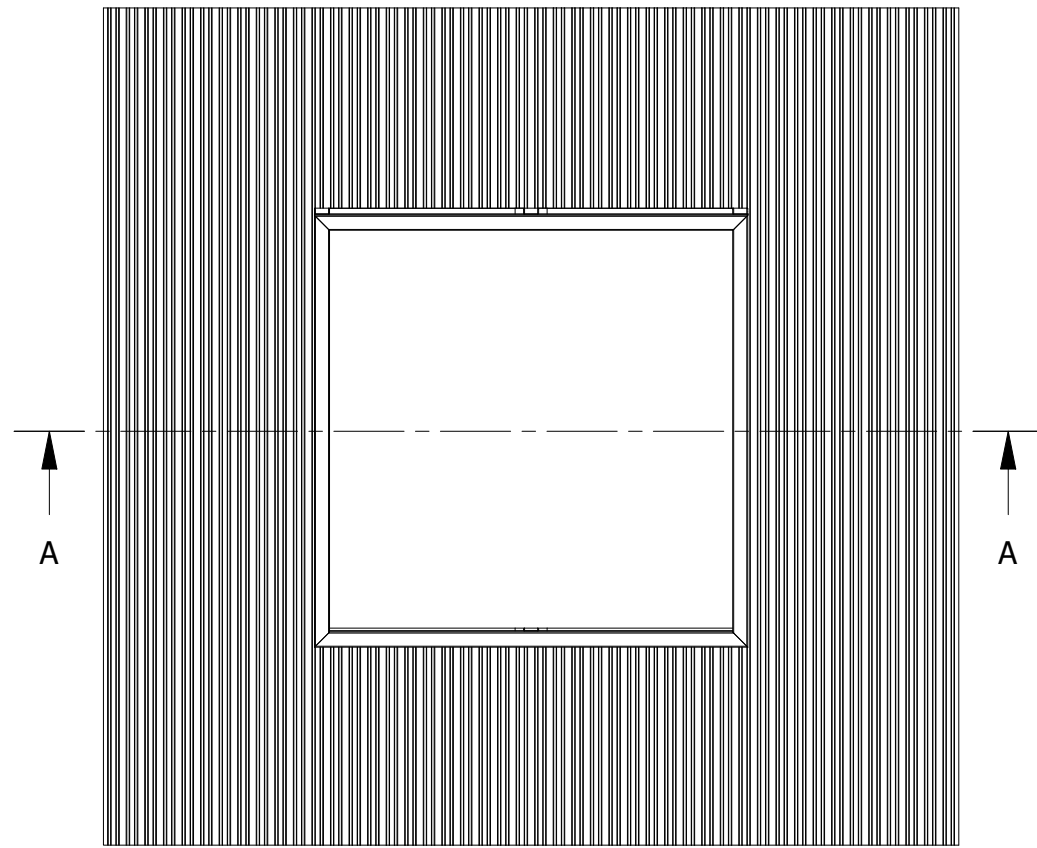

TOP VIEW  
SCALE 1 : 45

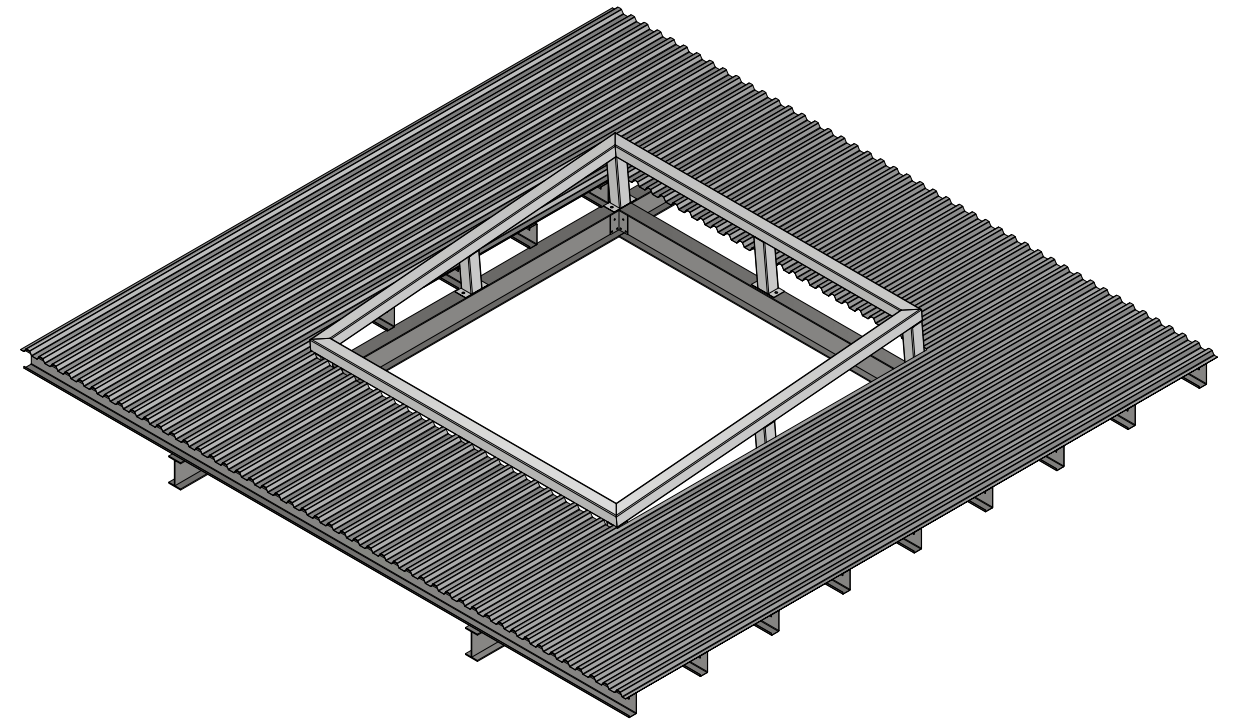

ISOMETRIC VIEW  
SCALE 1 : 45

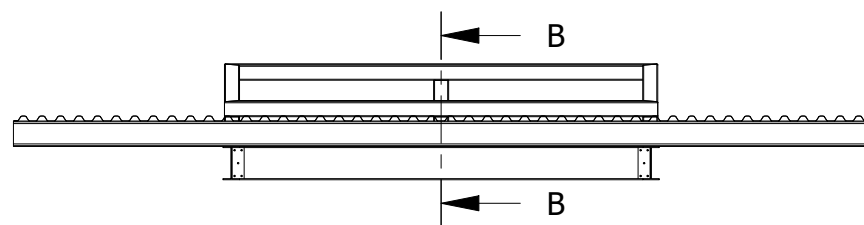

FRONT VIEW  
SCALE 1 : 45

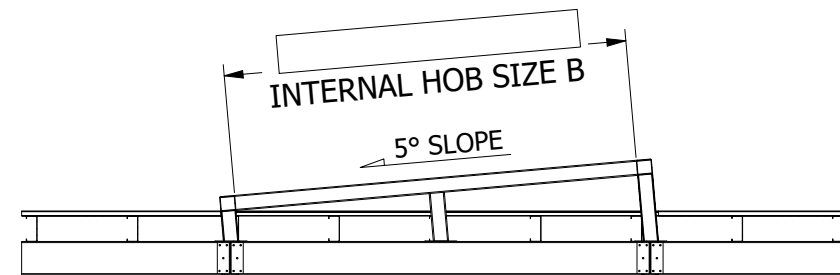

SECTION B-B  
SCALE 1 : 45

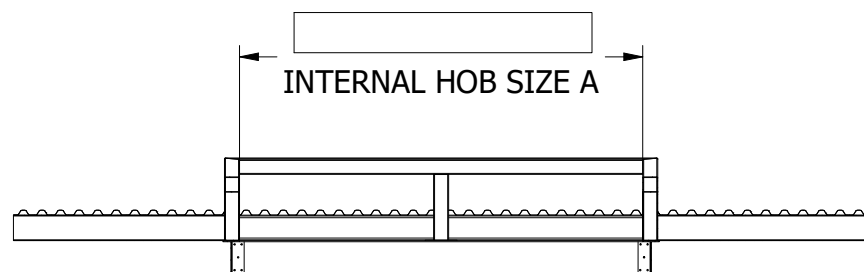

SECTION A-A  
SCALE 1 : 45

**Client Drawing Approval**  
**Name:**   
**Signature:**   
**Date:**

CLIENT:	DESIGNER: C.QUINOL	DATE CREATED: 10/07/2023	MATERIAL:	Skyspan Australia Pty Ltd 1 Gibbon Rd, Baulkham Hills NSW 2153, Australia Website: https://www.skyspan.com.au	
BUSINESS NAME:	DRAWN BY: C.QUINOL	DATE DRAWN: 19/02/2024	THICKNESS (FOR SHEET):		
PROJECT NAME:	MODIFIED BY: M.AMIT	DATE PROOFIFIED: 08/03/2024	FINISH/COLOR:	PART NUMBER: SB-2049-00	REVISION: A
QUOTE NUMBER:	CHECKED BY:	CHECKED DATE:	ESTIMATED MASS: N/A	VOLUME: N/A	TITLE: GXL - 5° STEEL HOB
WORK ORDER NUMBER:	APPROVED BY:	APPROVED DATE:	SCALE: DO NOT SCALE	FILENAME: SB-2049-00.iam	SHEET 3 OF 8
REFERENCE ORDER NUMBER:	TOLERANCES UNLESS OTHERWISE SPECIFIED IN MM COPYRIGHT: THE DESIGN DETAILS SHOWN ON THIS DRAWING ARE SPECIFIC TO THIS PROJECT ONLY AND MAY NOT BE REPRODUCED IN WHOLE OR IN PART OR BE USED FOR ANY OTHER PROJECT OR PURPOSE WITHOUT THE WRITTEN CONSENT OF SKYSPAN AUSTRALIA PTY LTD. ©COPYRIGHT 2024 SKYSPAN			SIZE: A3	
JOB NUMBER:	FLASHING #:	FLASHING QTY:	THIRD ANGLE PROJECTION		

This Skylight system is covered by Australian Patent Pending Number 2021901063 and New Zealand Patent Pending Number 774968.

Note: Flashing example shown as red is by others. Flashing details such as heights and widths and whether a back flashing to the ridge is used will be determined by the roofer.

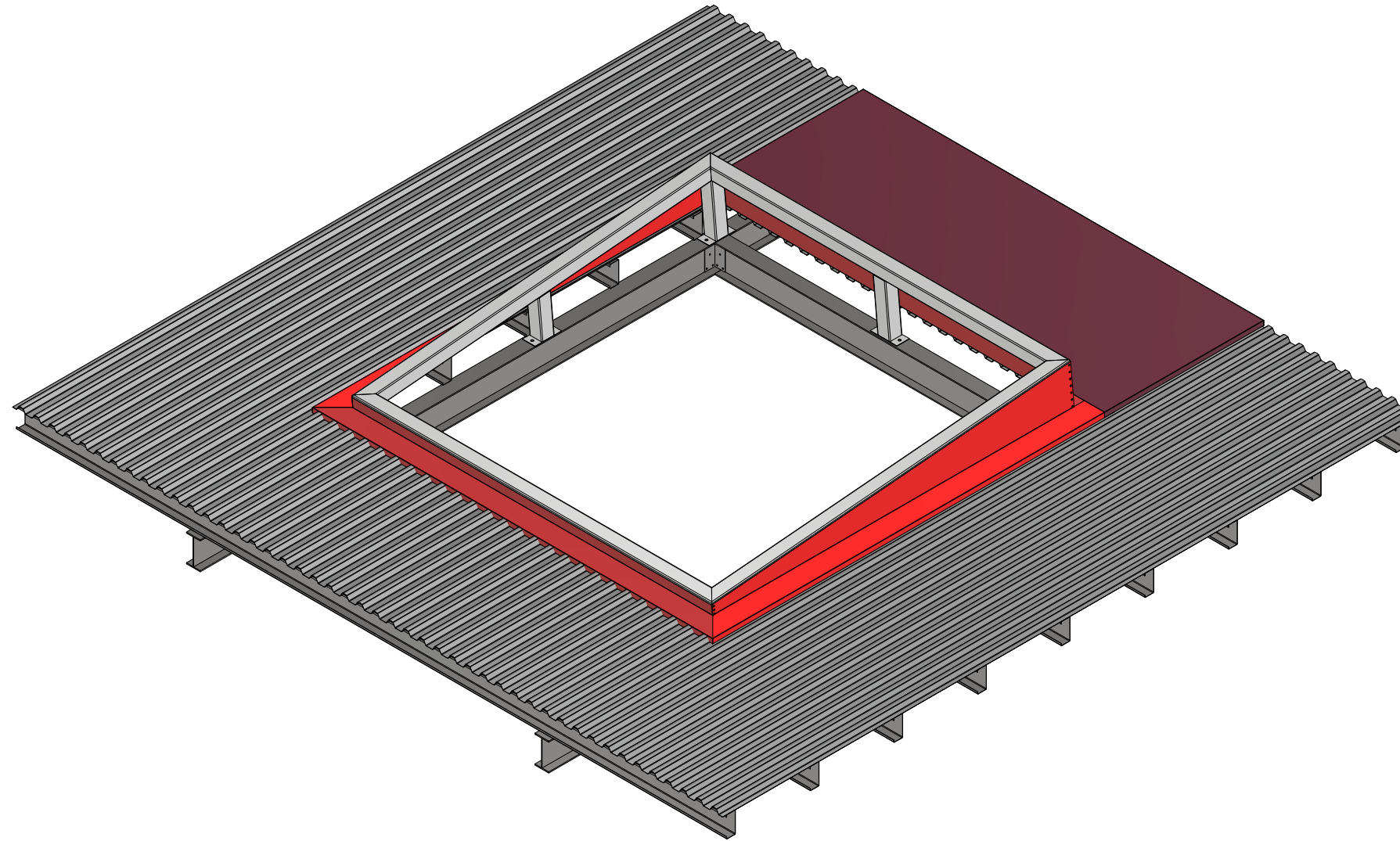

ISOMETRIC VIEW  
SCALE 1 : 30

CLIENT:	DESIGNER: C.QUINOL	DATE CREATED: 10/07/2023	MATERIAL:	Skyspan Australia Pty Ltd 1 Gibbon Rd, Baulkham Hills NSW 2153, Australia Website: <a href="https://www.skyspan.com.au">https://www.skyspan.com.au</a>		
BUSINESS NAME:	DRAWN BY: C.QUINOL	DATE DRAWN: 19/02/2024	THICKNESS (FOR SHEET):	PART NUMBER: SB-2049-00		
PROJECT NAME:	MODIFIED BY: M.AMIT	DATE MODIFIED: 08/03/2024	FINISH/COLOR:	ESTIMATED MASS: N/A		
QUOTE NUMBER:	CHECKED BY:	CHECKED DATE:	VOLUME: N/A	TITLE: GXL - 5° STEEL HOB		
WORK ORDER NUMBER:	APPROVED BY:	APPROVED DATE:	SIZE A3	SCALE: DO NOT SCALE		
REFERENCE ORDER NUMBER:	TOLERANCES UNLESS OTHERWISE SPECIFIED IN MM		THIRD ANGLE PROJECTION	FILENAME: SB-2049-00.iam		SHEET 4 OF 8
JOB NUMBER:	FLASHING #:	COPYRIGHT: THE DESIGN DETAILS SHOWN ON THIS DRAWING ARE SPECIFIC TO THIS PROJECT ONLY AND MAY NOT BE REPRODUCED IN WHOLE OR IN PART OR BE USED FOR ANY OTHER PROJECT OR PURPOSE WITHOUT THE WRITTEN CONSENT OF SKYSPAN AUSTRALIA PTY LTD. ©COPYRIGHT 2024 SKYSPAN				
	FLASHING QTY:					

This Skylight system is covered by Australian Patent Pending Number 2021901063 and New Zealand Patent Pending Number 774968.

Note: Flashing example shown as red is by others. Flashing details such as heights and widths and whether a back flashing to the ridge is used will be determined by the roofer.

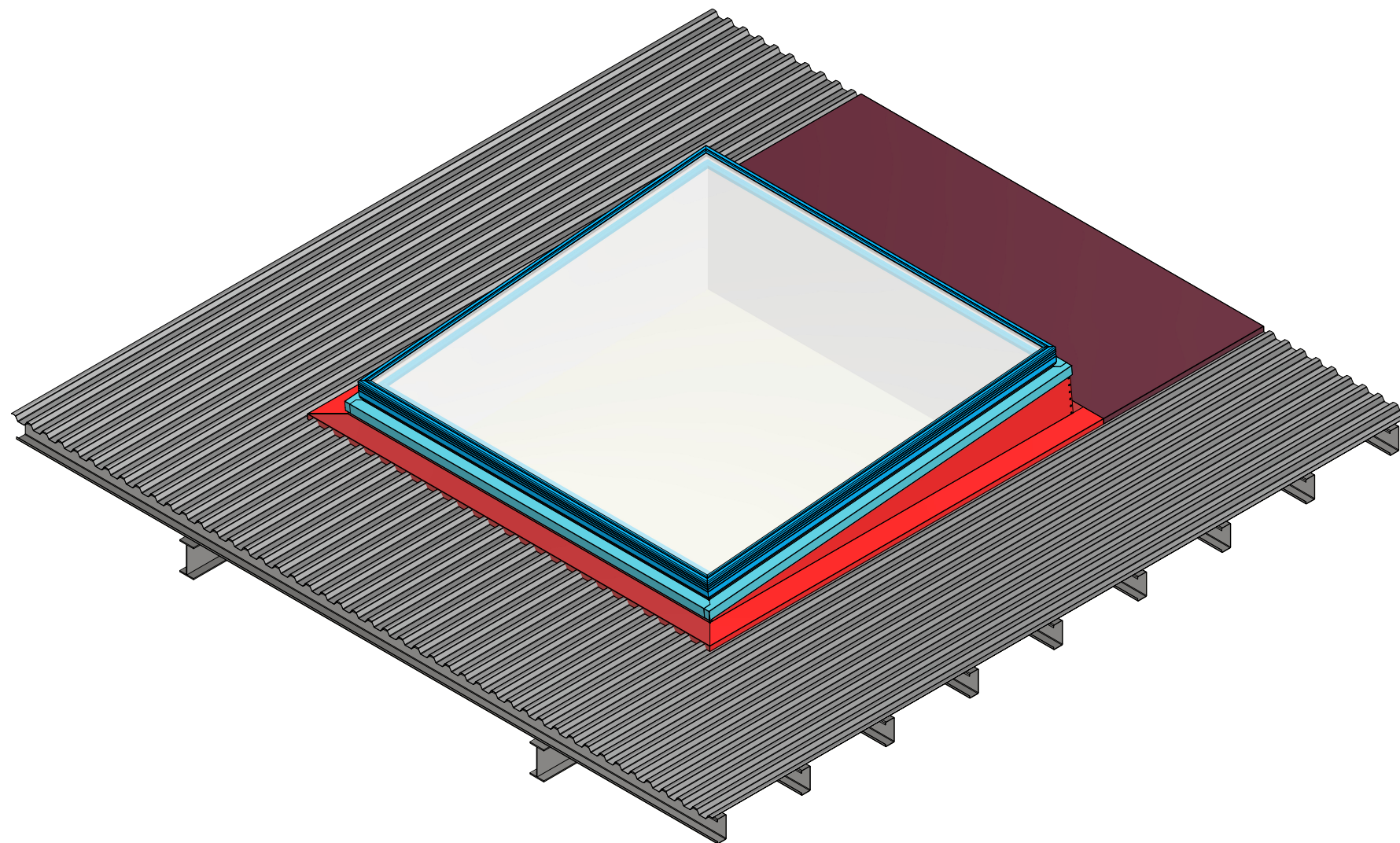

ISOMETRIC VIEW  
SCALE 1 : 30

CLIENT:	DESIGNER: C.QUINOL	DATE CREATED: 10/07/2023	MATERIAL:	Skyspan Australia Pty Ltd		
BUSINESS NAME:	DRAWN BY: C.QUINOL	DATE DRAWN: 19/02/2024	THICKNESS (FOR SHEET):	1 Gibbon Rd, Baulkham Hills NSW 2153, Australia Website: <a href="https://www.skyspan.com.au">https://www.skyspan.com.au</a>		
PROJECT NAME:	MODIFIED BY: M.AMIT	DATE MODIFIED: 08/03/2024	FINISH/COLOR:	PART NUMBER: SB-2049-00	REVISION A	
QUOTE NUMBER:	CHECKED BY:	CHECKED DATE:	ESTIMATED MASS: N/A	VOLUME: N/A	TITLE: GXL - 5° STEEL HOB	
WORK ORDER NUMBER:	APPROVED BY:	APPROVED DATE:	SIZE A3		SCALE: DO NOT SCALE	
REFERENCE ORDER NUMBER:	TOLERANCES UNLESS OTHERWISE SPECIFIED IN MM		THIRD ANGLE PROJECTION		FILENAME: SB-2049-00.iam	SHEET 5 OF 8
JOB NUMBER:	FLASHING #:	COPYRIGHT: THE DESIGN DETAILS SHOWN ON THIS DRAWING ARE SPECIFIC TO THIS PROJECT ONLY AND MAY NOT BE REPRODUCED IN WHOLE OR IN PART OR BE USED FOR ANY OTHER PROJECT OR PURPOSE WITHOUT THE WRITTEN CONSENT OF SKYSPAN AUSTRALIA PTY LTD. ©COPYRIGHT 2024 SKYSPAN				
	FLASHING QTY:					

This Skylight system is covered by Australian Patent Pending Number 2021901063 and New Zealand Patent Pending Number 774968.

FILL IN ALL BOXES PROVIDED.

D

C

B

A

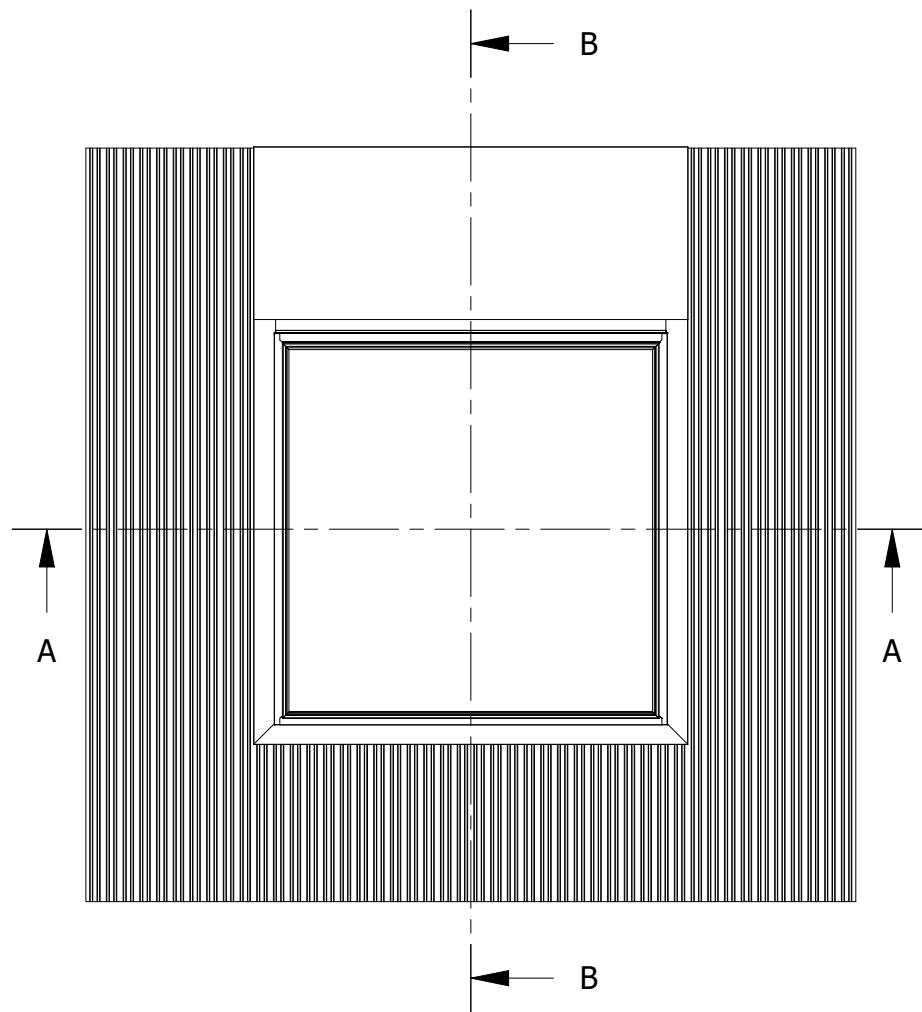

TOP VIEW  
SCALE 1 : 50

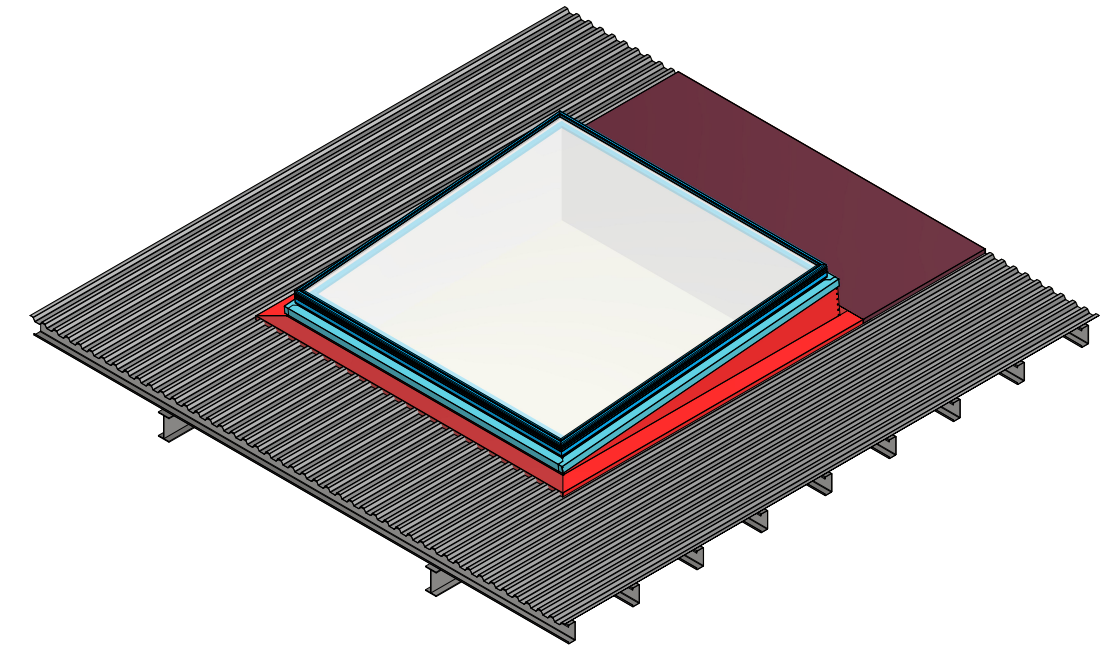

ISOMETRIC VIEW  
SCALE 1 : 50

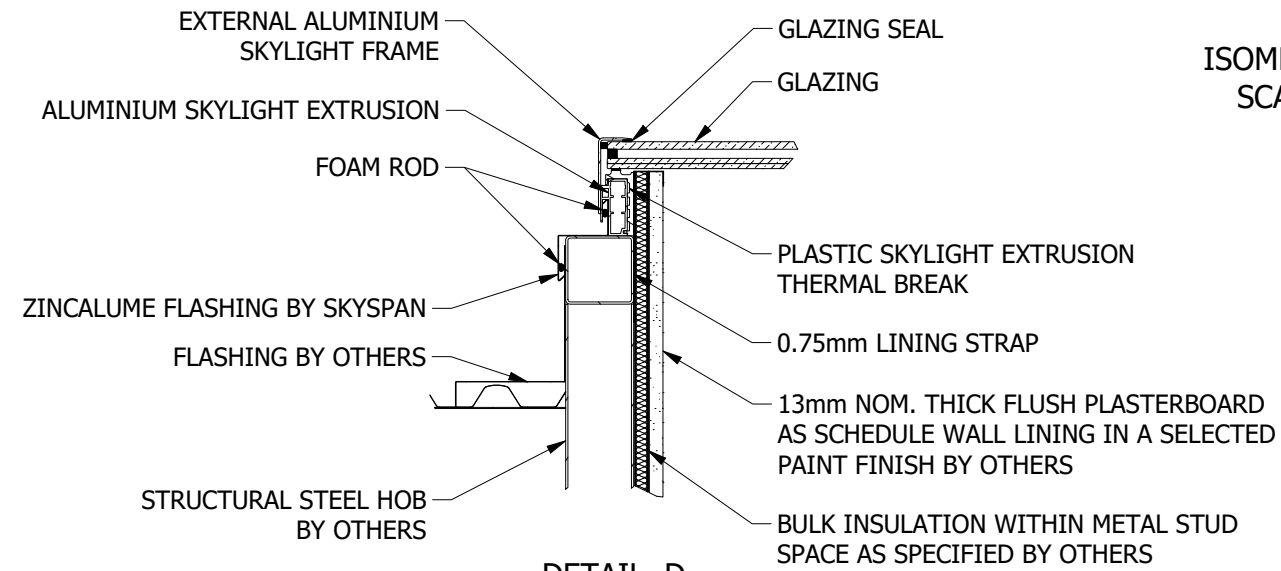

DETAIL D  
SCALE 1 : 10

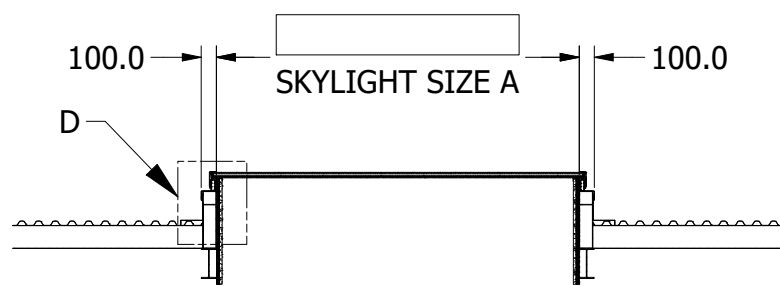

SECTION A-A  
SCALE 1 : 50

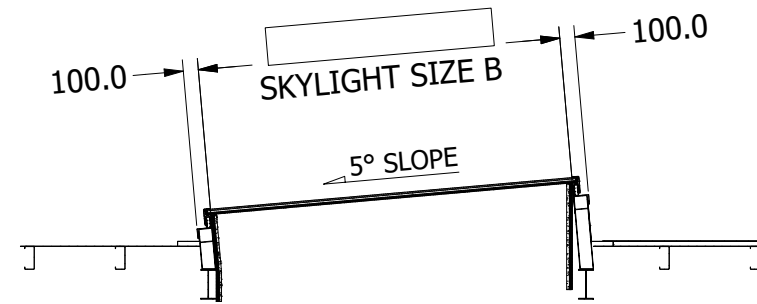

SECTION B-B  
SCALE 1 : 50

**Client Drawing Approval**

Name:

Signature:

Date:

CLIENT:	DESIGNER: C.QUINOL	DATE CREATED: 10/07/2023	MATERIAL:	<b>Skyspan Australia Pty Ltd</b> 1 Gibbon Rd, Baulkham Hills NSW 2153, Australia Website: <a href="https://www.skyspan.com.au">https://www.skyspan.com.au</a>	
BUSINESS NAME:	DRAWN BY: C.QUINOL	DATE DRAWN: 19/02/2024	THICKNESS (FOR SHEET):		
PROJECT NAME:	MODIFIED BY: M.AMIT	DATE MODIFIED: 08/03/2024	FINISH/COLOR:	PART NUMBER: SB-2049-00	REVISION A
QUOTE NUMBER:	CHECKED BY:	CHECKED DATE:	ESTIMATED MASS: N/A	VOLUME: N/A	
WORK ORDER NUMBER:	APPROVED BY:	APPROVED DATE:	SIZE A3	TITLE: GXL - 5° STEEL HOB	
REFERENCE ORDER NUMBER:	TOLERANCES UNLESS OTHERWISE SPECIFIED IN MM			SCALE: DO NOT SCALE	FILENAME: SB-2049-00.iam
JOB NUMBER:	FLASHING #:	COPYRIGHT: THE DESIGN DETAILS SHOWN ON THIS DRAWING ARE SPECIFIC TO THIS PROJECT ONLY AND MAY NOT BE REPRODUCED IN WHOLE OR IN PART OR BE USED FOR ANY OTHER PROJECT OR PURPOSE WITHOUT THE WRITTEN CONSENT OF SKYSPAN AUSTRALIA PTY LTD. ©COPYRIGHT 2024 SKYSPAN			SHEET 6 OF 8
	FLASHING QTY:				

This Skylight system is covered by Australian Patent Pending Number 2021901063 and New Zealand Patent Pending Number 774968.

6 5 4 3 2 1

FILL IN ALL BOXES PROVIDED.

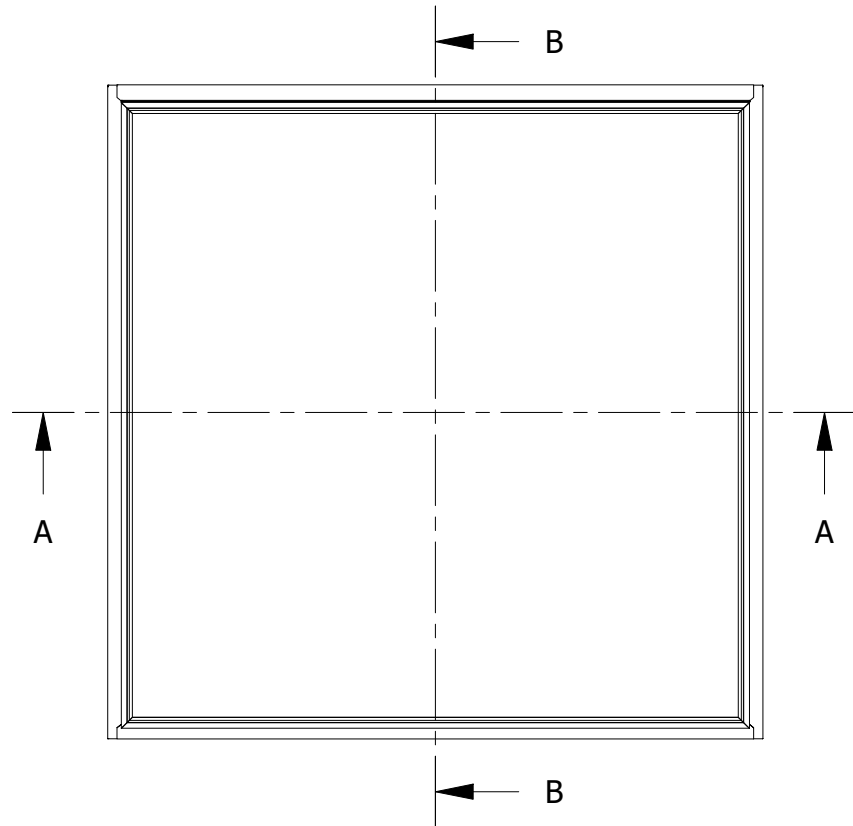

TOP VIEW  
SCALE 1 : 30

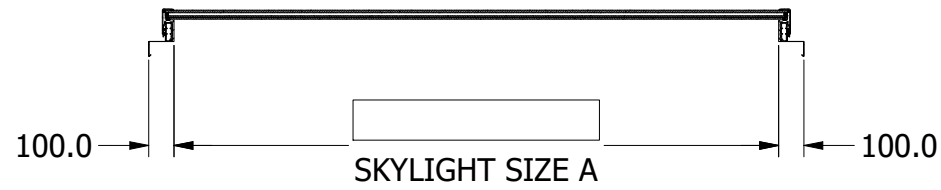

SECTION A-A  
SCALE 1 : 30



SECTION B-B  
SCALE 1 : 30

**Client Drawing Approval**  
**Name:**   
**Signature:**   
**Date:**

CLIENT:	DESIGNER: C.QUINOL	DATE CREATED: 10/07/2023	MATERIAL:	Skyspan Australia Pty Ltd 1 Gibbon Rd, Baulkham Hills NSW 2153, Australia Website:https://www.skyspan.com.au	
BUSINESS NAME:	DRAWN BY: C.QUINOL	DATE DRAWN: 19/02/2024	THICKNESS (FOR SHEET):		
PROJECT NAME:	MODIFIED BY: M.AMIT	DATE MODIFIED: 08/03/2024	FINISH/COLOR:	PART NUMBER: SB-2049-00	REVISION: A
QUOTE NUMBER:	CHECKED BY:	CHECKED DATE:	ESTIMATED MASS: N/A	VOLUME: N/A	
WORK ORDER NUMBER:	APPROVED BY:	APPROVED DATE:	SIZE <b>A3</b>		
REFERENCE ORDER NUMBER:	TOLERANCES UNLESS OTHERWISE SPECIFIED IN MM				
JOB NUMBER:	FLASHING #:	COPYRIGHT: THE DESIGN DETAILS SHOWN ON THIS DRAWING ARE SPECIFIC TO THIS PROJECT ONLY AND MAY NOT BE REPRODUCED IN WHOLE OR IN PART OR BE USED FOR ANY OTHER PROJECT OR PURPOSE WITHOUT THE WRITTEN CONSENT OF SKYSPAN AUSTRALIA PTY LTD. ©COPYRIGHT 2024 SKYSPAN AUSTRALIA PTY LTD.			SCALE: DO NOT SCALE
	FLASHING QTY:	FILENAME: SB-2049-00.iam			SHEET 7 OF 8

This Skylight system is covered by Australian Patent Pending Number 2021901063 and New Zealand Patent Pending Number 774968.

SKYSPAN RECOMMENDS MINIMUM OF 10MM ADDITIONAL CLEARANCE FOR FLASHING TO ALL SIDES TO ALLOW FOR HOB DISCREPANCIES. EACH HOB IS CONSTRUCTED DIFFERENT SO FLASHING CLEARANCE MUST BE SET BY THE CUSTOMER.

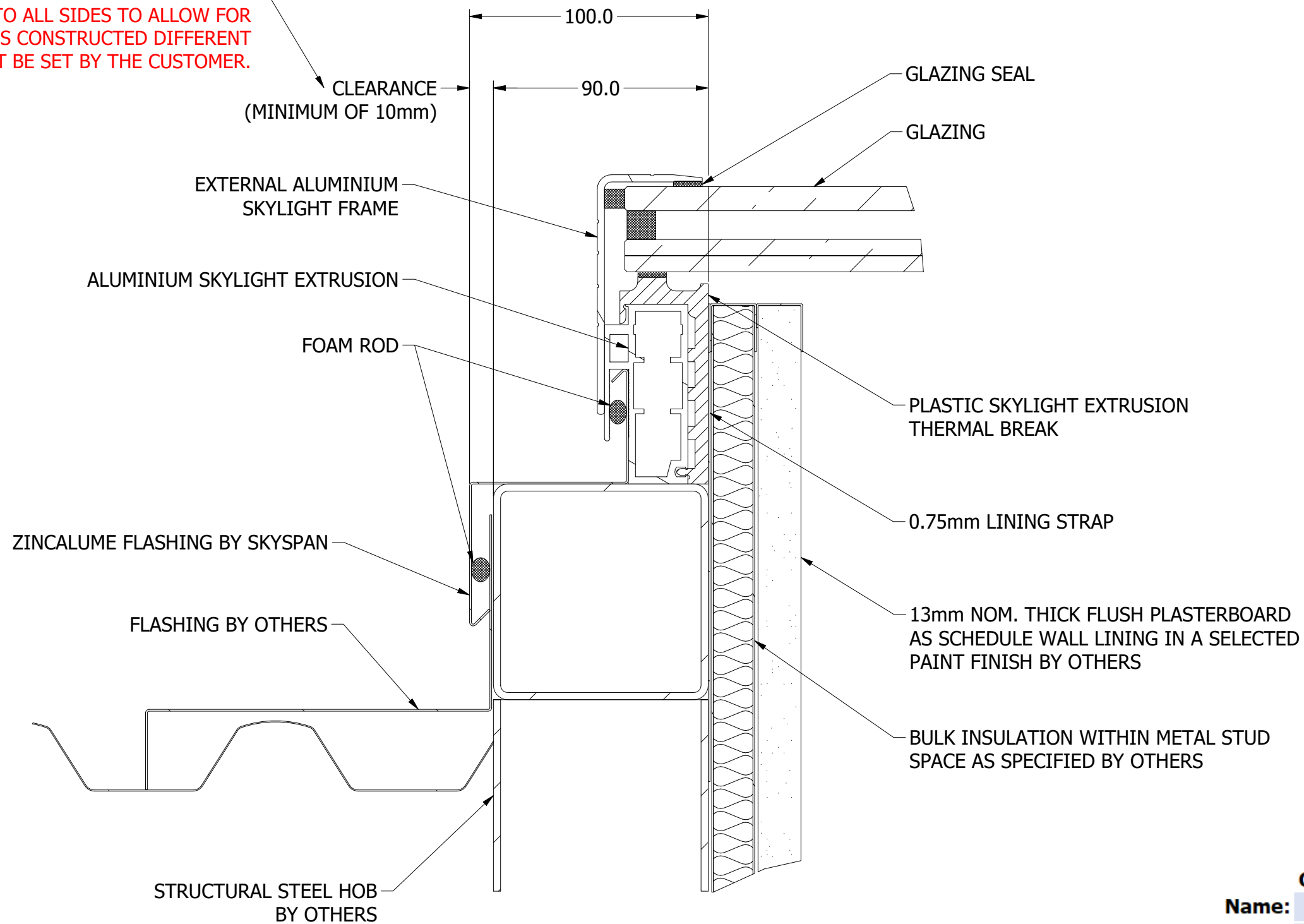

SECTION DETAIL VIEW  
SCALE 1 : 2

**Client Drawing Approval**  
**Name:**   
**Signature:**   
**Date:**

This Skylight system is covered by Australian Patent Pending Number 2021901063 and New Zealand Patent Pending Number 774968.

CLIENT:	DESIGNER: C.QUINOL	DATE CREATED: 10/07/2023	MATERIAL:	Skyspan Australia Pty Ltd 1 Gibbon Rd, Baulkham Hills NSW 2153, Australia Website: https://www.skyspan.com.au	
BUSINESS NAME:	DRAWN BY: C.QUINOL	DATE DRAWN: 19/02/2024	THICKNESS (FOR SHEET):		
PROJECT NAME:	MODIFIED BY: M.AMIT	DATE MODIFIED: 08/03/2024	FINISH/COLOR:	PART NUMBER: SB-2049-00	REVISION A
QUOTE NUMBER:	CHECKED BY:	CHECKED DATE:	ESTIMATED MASS: N/A	VOLUME: N/A	TITLE: GXL - 5° STEEL HOB
WORK ORDER NUMBER:	APPROVED BY:	APPROVED DATE:	SCALE: DO NOT SCALE	FILENAME: SB-2049-00.iam	SHEET 8 OF 8
REFERENCE ORDER NUMBER:	TOLERANCES UNLESS OTHERWISE SPECIFIED IN MM			SIZE A3	
JOB NUMBER:	FLASHING #:	COPYRIGHT: THE DESIGN DETAILS SHOWN ON THIS DRAWING ARE SPECIFIC TO THIS PROJECT ONLY AND MAY NOT BE REPRODUCED IN WHOLE OR IN PART OR BE USED FOR ANY OTHER PROJECT OR PURPOSE WITHOUT THE WRITTEN CONSENT OF SKYSPAN AUSTRALIA PTY LTD. ©COPYRIGHT 2024 SKYSPAN			
	FLASHING QTY:				